

Bar code

TOSHIBA

OWNER'S MANUAL

43C350KN/43C350KV/43C350KW/43C350KE
50C350KN/50C350KV/50C350KW/50C350KE
55C350KN/55C350KV/55C350KW/55C350KE
65C350KN/65C350KV/65C350KW/65C350KE

Owner's Record

You will find the model number and serial number on the back of the TV. Record these numbers in the spaces provided below. Refer to them whenever you call upon your Toshiba dealer regarding this product.

Model number:

Serial number:

Contents

Welcome to Toshiba

- Thank you for purchasing this Toshiba LED TV. This manual will help you use the exciting features of your new TV.
- Instructions in this manual are based on using the remote control.
- Please read all safety and operating instructions in this manual carefully, and keep this manual for future reference.
- LED TV is LCD Panel with LED Backlight.

Contents

Content	1
Important Safety Precautions	2
Getting Started	5
Accessories List	5
Installing the Stand or Wall Mount Bracket	5
TV Front	6
TV Rear	6
Terminals	8
Common Interface	8
Wired Setup	9
Wireless Setup	9
Connecting with an HDMI(ARC/eARC) Cable	9
Connecting with an HDMI Cable	9
Connecting with an USB Cable	9
Connecting Bluetooth Devices	10
Using HDMI & CEC	10
Remote Control	11
Buttons on the Remote Control	11
Installing Batteries in the Remote Control	12
Pairing the Remote Control	12
Remote Control Operation Range	12
Live TV	13
Turning the TV on for the First Time	13
Channel Scan	13
Channel List	14
Channel Edit	14
Favourite	15
Guide (EPG)	15
PVR	16
Recording List	16
Timeshift	17
Multi-screen	18
Screen Sharing	18
Content Sharing	18
Smart Functions	19

Getting Familiar with the Home Screen	19
Using a VIDAA Account	20
Using Voice Service	20
Media	22
App	23
Installing Mobile App to Control your TV	23

Picture and Sound

Picture and Sound	24
Adjusting the Picture Quality	24
Game Mode Settings	26
Adjusting the Sound Quality	26
Speakers Settings	27
Using Headphones	27

Accessibility and System

Accessibility and System	28
Accessibility	28
Setting Time	28
Using the Timer	28
Using Parental Control	28
Setting Language and Location	29
Using Power Indicator	29
Enhanced Viewing	29
Setting Usage Mode	29
Using Remote Control Service	29
Upgrade	30
Reset to Factory Default	30

Troubleshooting

Troubleshooting	31
Picture Issues	31
Sound Issues	31
Network Issues	31
External Device Connection Issues	32
Apps	32
Media Files	32
Voice Service Issues	32
TV Status Diagnosis	32
Recording/Timeshift Issues	33
Other Issues	33

Other Information

Other Information	34
Specifications	34
License Information	35

Disclaimer:

Images throughout this document are for illustrative purposes only and may differ from the actual product.

Designs and specifications are subject to change without notice.

Important Safety Precautions

Be sure to observe the following instructions and precautions to ensure safe use of this TV.

Installation

1. **WARNING: To prevent injury, this apparatus must be securely attached to a stable surface/wall in accordance with the installation instructions.**

Install the TV in a horizontal, stable location.

- If the TV is not installed securely, it may lean or fall over and cause an injury.
- To prevent injury, use the exclusive optional stand or wall-hanging bracket to install this TV on a stable surface or wall securely in accordance with a qualified technician.
- To secure the TV, use a sturdy strap from the hook(s) on the rear of the TV to a wall stud, pillar, or other immovable structure. Make sure the strap is tight, secure, and parallel to the floor.

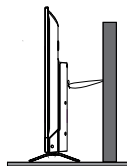

Only for the model with P-clip

2. **Never place the TV in an unstabilized location such as on a shaky table, incline or location subject to vibration.**

- Only use cabinets or stands recommended by the TV manufacturer.
- Only use furniture that can safely support the TV.
- Ensure that the TV is not hanging over the edge of the supporting furniture.
- Never place the TV on tall furniture (for example, cupboards or bookcases) without anchoring both the furniture and the TV to a suitable support.
- Never stand the TV on cloth or other material placed between the TV and supporting furniture.

The TV may drop or fall off, which may cause an injury or damage.

3. **Never stand or climb on the TV.**

- Educate children about the dangers of climbing on furniture to reach the TV or its controls.

Be especially careful in households with children to prevent them through climbing on top of the TV. It may move, fall over, break, become damaged or cause an injury.

4. **Always connect the power plug to an appropriate electrical outlet equipped with 100-240V AC, 50/60Hz.**

Never use the TV outside the specified voltage range. It may cause a fire or an electric shock.

About the fuse

In a three pin earthing-type, the fuse fitted in this plug is approved by ASTA or BSI to BS1362. It should only be replaced by a correctly rated and approved type and the fuse cover must be refitted.

About the use

- Make sure to insert the plugs firmly, when plugging the AC power cord into the TV set end and wall outlet end.
- Make sure to hold the plug, when unplugging the AC power cord.
- Never use other cord except for supplied AC power cord, and never use the supplied power cord for any other purpose.

5. **Never insert or remove the power plug with wet hands.**

This may cause an electric shock.

6. **Never block or cover the slots and openings in the cabinet.**

- Never place the TV so that it is facing upward or on its side.

- Never place the TV in a closet, bookcase or other similar area where the ventilation is poor.
- Never drape a newspaper, tablecloth or curtain on the TV.
- When installing the TV against a wall, always keep the TV at least 10cm away from the wall.
- Never place the TV on a soft unstable surface, such as a carpet, or a cushion.

The inside of this TV will overheat if the ventilation holes are covered, blocked or sealed, which may result in a fire.

7. **Never place the TV near a heater or in direct sunlight.**

The surface of the cabinet or power cord may melt and result in a fire or an electric shock.

8. **Never place the TV in an area exposed to high humidity levels, such as in a bathroom or close to a humidifier.**

This may cause a fire or an electric shock.

9. **Never place the TV next to a stove where it will be exposed to oil, smoke, or steam, or in a location where there is a large quantity of dust.**

This may cause a fire or an electric shock.

10. **Precautions for moving the TV.**

- When moving the TV, be sure to remove the plug from the wall outlet and disconnect the aerial cable and audio/video cables, any steady ties and mounting screw. A fire or an electric shock may result if the power cord is damaged.
- When carrying the TV, at least two people are needed. Be sure to carry it upright.
- Never carry the TV with the screen facing up or down.

11. **Precautions for installing on outdoor aerial.**

An outside aerial system should not be located in the vicinity of overhead power lines, or other electric light or power circuits.

If the aerial falls down or drops, it may cause an injury or an electric shock.

Use

1. **Never place hot objects or open flame sources, such as lighted candles or nightlights, on or close to the TV.**

High temperatures can melt plastic and lead to fires.

2. **The apparatus shall not be exposed to dripping or splashing and that no objects filled with liquids, such as vases, shall be placed on the apparatus.**

When liquids are spilled or small items are dropped inside the TV, this may cause a fire or an electric shock.

If small objects drop inside the TV, turn off the TV and remove the power plug from the outlet immediately and contact a service technician.

3. **Never insert objects (metal or paper) or pour water inside the TV through ventilation holes and other openings.**

These items may cause a fire or an electric shock. If these objects are inserted inside the TV, turn off the TV and remove the power plug from the outlet immediately and contact a service technician. Be especially careful that children do not insert objects in the TV.

4. **When the TV will not be used for a long period of time, such as during vacation or travel, remove the power plug from the wall outlet for safety.**

Important Safety Precautions

The TV is not completely disconnected from the power supply line, as minute current is consumed even when the Power switch is turned off.

The Mains plug or an appliance coupler is used as the disconnect device, therefore the disconnect device shall remain readily operable.

5. Never pull on the power cord when removing the plug from the wall outlet.

Always hold the plug firmly when removing it. If the power cord is yanked, the cord may become damaged and a fire or an electric shock may occur.

6. Never cut, break, modify, twist, bunch up or bent the cord or apply excessive force or tension to it.

Never place heavy objects on the cord or allow it to overheat as this may cause damage, a fire or an electric shock. Contact a service technician if the power cord is damaged.

7. If there is thunder or lightning, never touch the aerial cable or other connected cables.

You may suffer an electric shock.

8. Turn off the TV before unplugging the power cord.

Failure to do so, may cause a malfunction.

9. Listening to music at high volume levels and for extended durations can damage one's hearing.

In order to reduce the risk of damage to hearing, one should lower the volume to a safe, comfortable level, and reduce the amount of time listening at high levels.

10. In dry environment due to static electricity, the product may be restart and return to the main OSD interface, USB player interface or the previous source mode.

You can continue to use the TV when appear this phenomenon.

Service

1. Never repair, modify or disassemble the TV by yourself.

It may cause a fire or an electric shock.

Consult a service technician for inspection and repairs.

2. When a malfunction occurs, or if smoke or an unusual odor comes from the TV, turn off the TV and remove the power plug from the outlet immediately.

Make sure that the smoke or smell has stopped, then contact a service technician. If the TV is still used in this condition, it may cause a fire or an electric shock.

3. If the TV is dropped or the cabinet is broken, turn off the TV and remove the power plug from the outlet immediately.

If the TV has power in this condition, it may cause a fire or an electric shock. If the cabinet is broken, be careful when handling the TV to prevent an injury.

Contact a service technician for inspection and repair.

4. When the TV reaches the end of its useful life, ask a qualified service technician to properly dispose of the TV.

Cleaning

CAUTION: Avoid using chemicals (such as air refreshers, cleaning agents, etc.) on or near the TV pedestal. Studies indicate that plastics may weaken and crack over time from the combination effects of chemical agents and mechanical stress (such as weight of TV). Failure to follow these instructions could result in serious injury and/or permanent damage to TV and TV pedestal.

1. Remove the power plug before cleaning.

Never use solvents such as benzine or thinner to clean the TV.

- These solvents may distort the cabinet or damage its finish.
- If rubber or vinyl products remain in contact with the TV for a long time, a stain may result.

If the cabinet becomes dirty, clean it with a soft, dry cloth.

When cleaning the surface of the LED display, wipe the panel surface gently with a soft, dry cloth.

2. Periodically disconnect the power plug from the outlet and check it.

If dust has collected on the power plug connectors, clean off the dust with a dry cloth.

This dust may cause a fire due to reduced insulation on the plug.

Important information

1. About LCD screen

- If you have the LCD screen facing to the sun, the LCD screen will be damaged. Be aware of locating the TV close to a window or outdoors.
- Never press the LCD screen strongly or scratch it, and never put anything on it. These actions will damage the LCD screen.

2. About cabinet and LCD screen

Never spray volatile compounds such as insecticide on the cabinet and LCD screen. This may cause a discoloration or damage the cabinet and LCD screen.

3. About afterimage

If a still picture is displayed, an afterimage may remain on the screen, however it will disappear. This is not a sign of malfunction.

4. Some pixels of the screen do not light up

The LCD display panel is manufactured using an extremely high level of precision technology, however sometimes some pixels of the screen may be missing picture elements or have luminous spots. This is not sign of malfunction.

5. About Interference

The LCD display may cause interference in image, sound, etc. of other electronic equipment that receives electromagnetic waves (e.g. AM radios and video equipment).

6. About using under the low temperature places

If you use the TV in the room of 0°C or less, the picture brightness may vary until the LCD monitor warms up. This is not a sign of malfunction.

7. When disposing of or transferring ownership of the TV

Before disposing of or transferring ownership of the TV, perform "Resetting the TV".

Important Safety Precautions

Recording using an USB storage device

- Be sure to select the correct country/region for use.
Use of the recording function may not be possible depending on the selected country/region.
Use with incorrect settings may violate certain laws or other regulations, and may result in criminal punishment.
In such cases, TOSHIBA CORPORATION and the Toshiba Group shall bear no responsibility whatsoever.
- The recording function has been designed for private use and entertainment in your home environment.
Please note that any commercial use of the recording function could lead to copyright infringement of authors' rights. Toshiba asks you to respect the intellectual property rights of third parties.
- Before recording to a device connected to the TV, make a test recording and check the recording performance.
- Toshiba shall not be liable for compensation or incidental damages of any kind whatsoever resulting from content that was not properly recorded on the recording device or that was modified or lost.
- Toshiba shall not be liable for damages of any kind whatsoever (breakdown of the recording device, modification or loss of the recorded content, etc.) resulting from malfunction, operating failure or incorrect operation due to combining with another connected device.
- Do not turn off the power supply to the USB storage device or disconnect the connecting cable while the USB storage device is operating. Doing so may result in loss of the recorded data or malfunction of the USB storage device.
- The recording function is not available in all countries/regions.
- Please note that recording on the USB storage device is no longer playable after the TV's main-board is exchanged during service.
- If the time information is incorrect, programmed recording may not be performed properly.
Furthermore, if the time information differs according to the currently viewed channel, programmed recording may not be performed properly depending on tuning operations.

Exemptions

- Toshiba is not liable for any damage caused by fires, natural disaster (such as thunder, earthquake, etc.), acts by third parties, accidents, owner's misuse, or uses in other improper conditions.
- Toshiba is not liable for incidental damaged (such as profit loss or interruption in business, modification or erasure of record data, etc.) caused by use or inability to use of product.
- Toshiba is not liable for any damage caused by neglect of the instructions described in the owner's manual.
- Toshiba is not liable for any damage caused by misuse or malfunction through simultaneous use of this product and the connected equipment.

When using a wireless network

CAUTION:

- Bluetooth™ and Wireless LAN devices operate within the same radio frequency range and may interfere with one another. If you use Bluetooth™ and Wireless LAN devices simultaneously, you may occasionally experience a less than optimal network performance or even lose your network connection.

- If you should experience any such problem, immediately turn off either your Bluetooth™ or Wireless LAN device.
- Actual performance can vary, including lower wireless network capacity, data throughput rate, range and coverage.
- Performance depends on many factors, conditions and variables, including distance from the access point, volume of network traffic, building materials and construction, operating system used, mix of wireless products used, interference and other adverse conditions.

Wireless LAN and your Health

Wireless LAN products, like other radio devices, emit radio frequency electromagnetic energy. The level of energy emitted by Wireless LAN devices, however, is far less than the electromagnetic energy emitted by wireless devices such as mobile phones.

Because Wireless LAN products operate within the guidelines found in radio frequency safety standards and recommendations, TOSHIBA believes Wireless LAN is safe for use by consumers. These standards and recommendation reflect the consensus of the scientific community and result from deliberations of panels and committees of scientists who continually review and interpret the extensive research literature.

In some situation or environments, the use of Wireless LAN may be restricted by the proprietor of the building or responsible representatives of the organization. Such restrictions may apply in environments where the risk of interference to other devices or services is perceived or identified as harmful.

If you are uncertain of the policy that applies to the use of wireless devices in a specific organization or environment, you are encouraged to ask for authorization to use the Wireless LAN device prior to turning on the equipment.

 This equipment is a Class II or double insulated electrical appliance.

It has been designed in such a way that it does not require a safety connection to electrical earth.

 AC voltage: This symbol indicates that the rated voltage marked with the symbol is AC voltage.

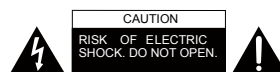

- This lightning flash with arrowhead symbol within an equilateral triangle is intended to alert the user to the presence of non-insulated "dangerous voltage" within the product's enclosure that may be of sufficient magnitude to constitute a risk of electric shock.
- Warning: To reduce the risk of electric shock, do not remove cover (or back) as there are no user serviceable parts inside. Refer servicing to qualified personnel.
- The exclamation point within an equilateral triangle is intended to alert the user to the presence of important operating and maintenance instructions in the literature accompanying the appliance.

Getting Started

Accessories List

The following accessories are included with TV:

OWNER'S MANUAL Base Stand × 2 Remote Control × 1
 AAA Battery × 2 Screw × 4 Power Cord × 1
 RCA jack to AV Cable × 1

NOTE

- The accessories may be different from the list above due to different models, countries/regions. Please refer to the actual accessory bag.

Installing the Stand or Wall Mount Bracket

CAUTION

- Be sure to disconnect the AC power cord before installing a stand or Wall-Mount brackets.
- The display on your TV is fragile. Make sure the TV screen is not scratched or damaged by hard objects or from pressure.
- After the installation is complete, make sure the TV is steady on a table or firmly attached to a wall mount, before removing all protective film, if any.

Installing the Stand

- Carefully place your TV face-down on a soft, flat surface to prevent damage to the TV or scratching to the screen.
- Remove the Base Stand from the accessory bag and then insert the stands into the bottom slots of the TV.
- Secure the Base Stand to the TV with the screws in accessory tightly.

43"/50"/55"

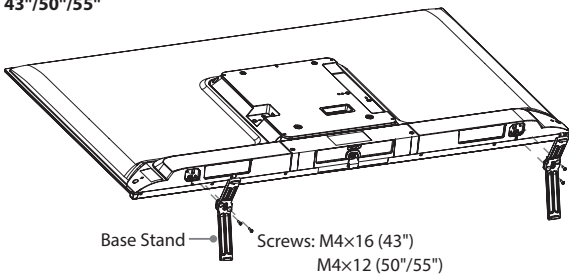

65"

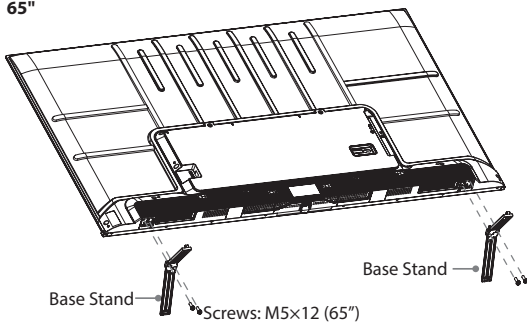

Installing the Wall Mount Bracket

Before mounting the TV, remove the TV stand if you have already attached it, and make sure the wall mount bracket supports the weight of your TV.

CAUTION

When mounting the TV on a wall, follow instructions provided with the wall mount bracket. If it is not correctly mounted, the TV may fall and cause property damage or personal injury.

- Place spacers between the TV and bracket.
- Make sure the tilt angle between the TV screen and the vertical surface is no more than 15 degrees.
- Standard dimensions are shown below.

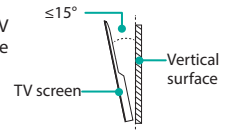

Wall mount hole pattern (mm)	200 × 300 (43"/50"/55") 400 × 300 (65")
Wall mount screw size	M6

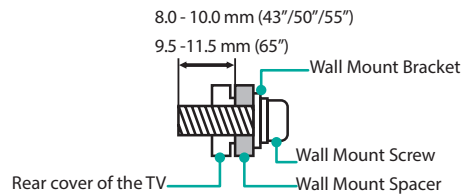

Follow instructions provided with the wall mount bracket.

NOTE

- The diameter and length of the screws differ depending on the wall mount bracket model.
- Wall mount bracket is optional. Your TV may not have wall mount bracket. Please refer to the actual accessories.

Installing the P-Clip

Please place the TV on a horizontally stable surface, and then use P-Clip to connect the TV and the wall or pillar.

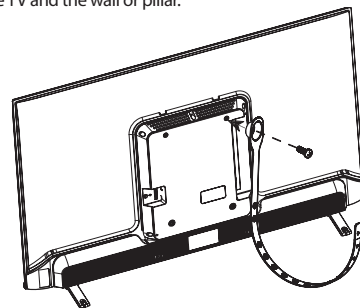

- Fix the larger side of P-Clip to the screw hole on the back of TV set with a M6x12 screw.
- Fix the other side of P-Clip to the wall or pillar with a ST4x25 screw.

NOTES

- Insecure installation may cause the tilt or falling of the product, and further lead to personal injuries or product damages.
- P-Clip and corresponding screws may not be included with TV set. Please purchase them by yourself if necessary.
- The picture is only for reference.

Getting Started

TV Front

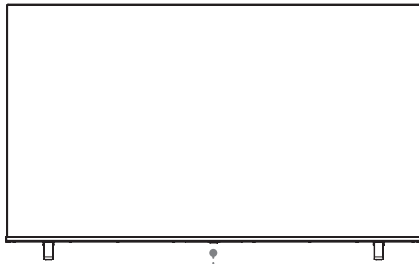

Remote sensor/Power indicator/Single button (Standby/Source)

Item	Description
Remote sensor	Receive remote signals from the remote control. Do not put anything near the sensor, as its function may be affected.
Power indicator	The light is red in standby mode, the light is off when TV is on.
Standby / Source	Press the single button when in standby mode, and the TV will be turned on. Press the single button to call up the menu. When the focus is on "Power Off", wait for 3 seconds, and then the TV will go into standby mode automatically. Press the single button to call up the menu, and then select among the different input signal sources.

TV Rear

43"/50"/55"

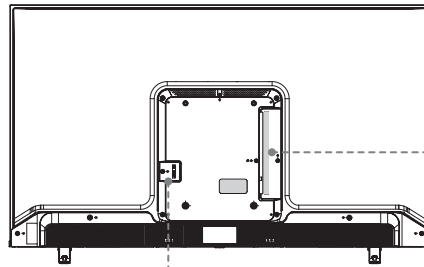

AC INPUT

NOTE

- Check the jacks for position and type before making any connections. Loose connections can result in image or colour problems. Make sure that all connections are tight and secure.
- Not all A/V devices have the ability to connect to a TV, please refer to the user's manual of your A/V device for compatibility and connections procedure.
- Before connecting external equipment, remove the mains plug from the wall socket. Otherwise, it may cause electric shock.
- Service jack is not available for you to connect an external device. It can only be used by our factory for testing purposes.



Getting Started

65"

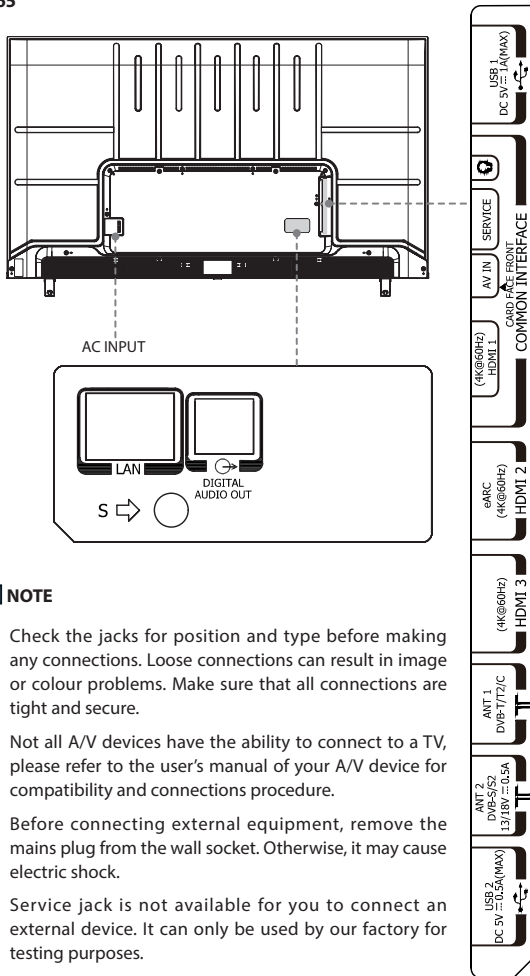











NOTE

- Check the jacks for position and type before making any connections. Loose connections can result in image or colour problems. Make sure that all connections are tight and secure.
- Not all A/V devices have the ability to connect to a TV, please refer to the user's manual of your A/V device for compatibility and connections procedure.
- Before connecting external equipment, remove the mains plug from the wall socket. Otherwise, it may cause electric shock.
- Service jack is not available for you to connect an external device. It can only be used by our factory for testing purposes.

Getting Started

Terminals

ANT DVB-T/T2/C		Connect an outdoor VHF/UHF antenna.
ANT DVB-S/S2		Connect an outdoor Satellite antenna.
HDMI		Connect an HDMI cable from an external A/V equipment.
HDMI(eARC)		Connect an HDMI cable from an external digital audio system.
AV IN		Connect a composite video cable and left-right audio cables from an external AV device. The VIDEO can be used to connect a range of equipment, including video recorders, camcorders, decoders, satellite receivers, DVD players, or games consoles.
USB		Connect a USB device for browsing photos, music and movies.
DIGITAL AUDIO OUT		Connect an optical cable from an external digital audio system.
LAN		Connect an Ethernet cable to access a network or the Internet.
COMMON INTERFACE		Insert the CI+ module for watching scrambled services like pay-tv channels or some HD channels.
HEADPHONE		Connect headphones to listen to the sound coming from the TV. Note: Excessive sound pressure from earphones can cause hearing loss.
SERVICE		This port is not available for you to connect an external device. It can only be used by our factory for testing purposes.

NOTE

- The location and names of the terminals on the TV may vary according to TV model, and not all terminals available on all models.

Common Interface

Insert the CI+ module for watching scrambled services like pay-tv channels or some HD channels.

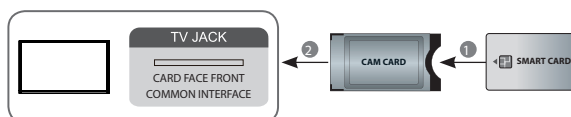

NOTE

- Before you insert/remove the CI+ module, ensure that the TV is switched off. Then insert the CI card into the CI+ module in accordance with the Service Provider's instructions.
- Do not repeatedly insert or remove the Common Access Module as this may damage the interface and cause a malfunction.
- You must obtain a CI+ module and card from the service provider of the channels you want to watch.
- Insert the CI+ module with the SmartCard in the direction marked on the module and SmartCard.
- CI+ is not supported in some countries/regions; check with your authorised dealer.

Getting Started

Wired Setup

Connect your TV to your network by connecting the LAN port on the back of your TV to an external modem or router using a LAN (Ethernet/Cat 5) cable.

See the illustration below.

NOTE

- You can get access to the Internet through your TV.
- It is recommended to use a modem or router that supports Dynamic Host Configuration Protocol (DHCP). Modems and routers that support DHCP automatically provide the IP address, subnet mask, gateway, and DNS, so you don't have to enter them manually. Most home networks already have DHCP.

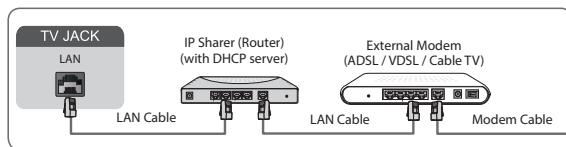

Wireless Setup

To connect your TV to your wireless network, you need a wireless router or modem. See the illustration below.

The TV's built-in Wireless LAN Adapter supports the IEEE802.11 a/b/g/n/ac communication protocols.

NOTE

- You can get access to the Internet through your TV.
- Connect to an available wireless network.
- Make sure that you have the wireless router's SSID and password before attempting to connect.

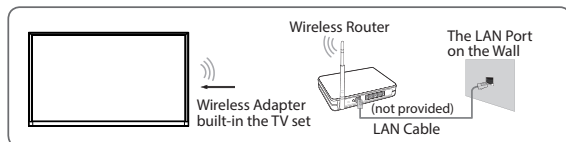

Connecting with an HDMI (ARC/eARC) Cable

If you'd like to use the Audio Return Channel (ARC)/the Enhanced Audio Return Channel (eARC) feature to send sound from the TV by an HDMI cable to a digital sound system, you can connect it to the HDMI (ARC/eARC) port of your TV.

By using this feature, you can also control the sound system with your TV remote instead of using the remotes for each device.

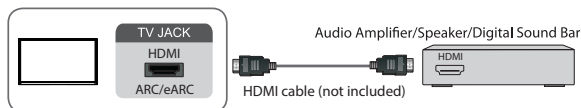

NOTE

- It works only when the TV is connected to the audio receiver that supports the ARC/eARC function.
- If the device has an Input Selector feature, then make sure to change it to the TV.

- When this port is used for ARC/eARC function, it can be used as signal input when a DVD is connected to an amplifier and the amplifier is connected to the TV at the same time. Some amplifiers may not support series connection.

Connecting with an HDMI Cable

Connect an HDMI cable from an external A/V equipment.

Some devices, such as DVD player, require HDMI signal to be set to output in the device's settings. Please consult your device user manual for instructions. Please note that the HDMI connector provides both video and audio signals, so it's not necessary to connect an audio cable.

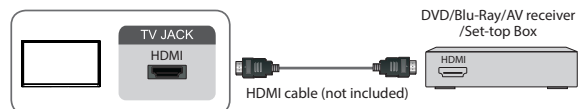

Connecting with a USB Cable

Connect the USB devices, such as hard drives, USB sticks and digital cameras for browsing photos, listening to music.

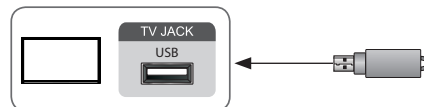

- Support the U disk 4G, 8G, 16G, 32G, 64G, 128G and other common market size, 8T hard drive is currently supported.
- Support format: NTFS, FAT32.

NOTE

- Be sure to select the correct country/region for use.
Use of the recording function may not be available depending on the selected country/region.
Use with incorrect settings may violate certain laws or other regulations, and may result in criminal punishment.
In such cases, TOSHIBA CORPORATION and the Toshiba Group shall bear no responsibility whatsoever.
- Recorded programmes saved on the USB storage device can only be viewed on this TV. They cannot be viewed when connected to another TV (including the same model of TV), a PC, or other device.
- You cannot watch one channel while recording another.
- If the recording time to the USB storage device is too short, no data may be saved.
- You cannot record video input signals on the USB device.
- Not all types of broadcast may be recordable.
- After programming the TV to record digital broadcasting, do not disconnect the power plug before recording starts.
- Should video or audio recording fail due to malfunction of the TV or poor reception, no compensation shall be paid.

Getting Started

Connecting Bluetooth Devices





You can connect to devices using Bluetooth technology.

NOTES

- Bluetooth function may not be applicable in some models/countries/ regions.

Connecting a Bluetooth device

To pair a Bluetooth device, such as Bluetooth headphones, speakers, keyboards, mouse or even mobile devices:



- Set  >  **Settings** > **Network** > **Bluetooth** to **On**.
- Before pairing your Bluetooth devices, make sure they're in pairing mode and put devices within pairing range. To put your Bluetooth devices in pairing mode, refer to the manual of devices.
- Find the Bluetooth device name in  >  **Settings** > **Network** > **Bluetooth** > **Equipment Management** and select it. The device will be automatically connected to the TV.

NOTE

- Only one Bluetooth speaker or Bluetooth headphone can be connected to the TV. If a new Bluetooth speaker or headphone connects to the TV, the old one will be disconnected automatically.
- Compatibility issues may occur depending on the Bluetooth device.
- Bluetooth keyboards may not be functional with some applications.
- The TV and Bluetooth devices may disconnect depending on the distance between them.

Listening to the audio through Bluetooth devices

Pair the Bluetooth audio devices using the TV's Bluetooth function. Refer to the user manual for your audio devices, such as Bluetooth speaker or sound bar, for detailed connection and usage.

After the Bluetooth connection is completed, go to  >  **Settings** > **Sound** > **Speakers** > **Audio Output**, and then select **BT Sound Bar** option to listen to the audio through bluetooth devices.

NOTE

- Compatibility issues may occur depending on the Bluetooth device.
- The TV and Bluetooth device may disconnect depending on the distance between them.

TV Bluetooth speaker

 >  **Settings** > **Network** > **Bluetooth** > **TV Bluetooth Speaker**

TV Output: Mobile devices are connected to TV with Bluetooth. Sound outputs via TV speaker.



When your mobile device is connected to the TV via Bluetooth, you can play your mobile phone's music through TV built-in speakers. This function makes the TV perform as a speaker.

Go to your mobile Settings to enable Bluetooth, and choose the TV to connect.

To use this function, make sure to select **TV Speaker** at  > **Settings** > **Sound** > **Speakers** > **Audio Output**.

Using HDMI & CEC

Use the TV remote to control external devices that are connected to the TV by an HDMI cable. The external devices need to support HDMI & CEC function.

 >  **Settings** > **System** > **HDMI & CEC**

Connecting an external device through HDMI & CEC function

 >  **Settings** > **System** > **HDMI & CEC** > **CEC Control**

Allow HDMI devices to control each other.

- Set **CEC Control** to **On**.
- Connect an HDMI & CEC compatible device to the TV.
- Turn on the connected external device. The device will be connected to the TV automatically. After connection is finished, you can access the menu of the connected device on your TV screen using your TV remote and control the device.
- When CEC control is enabled and HDMI & CEC compatible external devices are turned off, the TV will enter the standby mode. The function needs to be supported by the external device.

Enabling device auto power off

 >  **Settings** > **System** > **HDMI & CEC** > **Device Auto Power Off**

Set to **On** to turn off HDMI & CEC compatible external devices when the TV is turned off.

Enabling device auto power on

 >  **Settings** > **System** > **HDMI & CEC** > **Device Auto Power On**

Set to **On** to turn on HDMI & CEC compatible external devices when the TV is turned on.

This feature is applicable when TV input source is preset to the corresponding external device.

Enabling TV auto power on

 >  **Settings** > **System** > **HDMI & CEC** > **TV Auto Power On**

Set to **On** to turn on the TV when HDMI & CEC compatible external devices is turned on.

HDMI format function

 >  **Settings** > **System** > **HDMI & CEC** > **HDMI Format**

Please select **Enhanced format** if your HDMI device supports 4K HDR. If it does not support 4K HDR, please select **Standard format**. If you are not sure, please select **Auto**.

NOTE

- HDMI cables must be used to connect HDMI & CEC compatible devices to your TV.
- The HDMI & CEC feature of the connected device must be turned on.
- If you connect an HDMI device that is not HDMI & CEC compatible, all the HDMI & CEC control features do not work.
- Depending on the connected HDMI device, the HDMI & CEC control feature may not work.
- The HDMI & CEC feature supports One Touch Play, Routing Control, System Standby, Device OSD Name Transfer, Remote Control Pass Through, Give Device Power Status, System Audio Control.

Remote Control

Buttons on the Remote Control

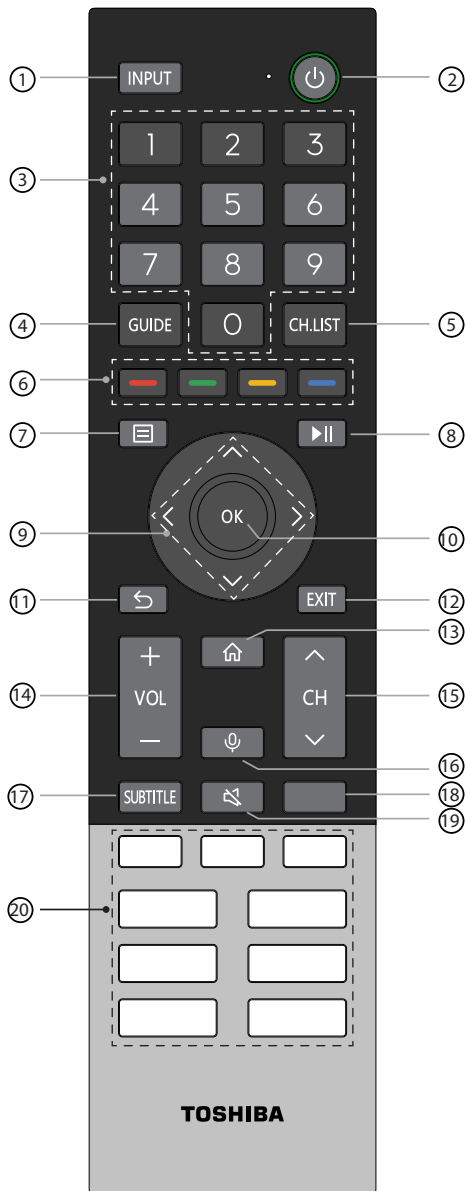

- ① INPUT: Select input source
- ② POWER: Switch the TV on or into standby mode
- ③ 0-9: Direct channel selection or numbers input
- ④ GUIDE: Display the Electronic Programme Guide (DTV mode)
- ⑤ CH.LIST: Display the Channel List on the screen
- ⑥ Red/Green/Yellow/Blue button: Colour keys for direct selection of options
- ⑦ : Display the Quick setup menu
- ⑧ : Media content control function buttons
- ⑨ $\wedge / \vee / < / >$: Allows you to navigate the OSD menus and adjust the system settings to your preference
- ⑩ OK: Confirm the selection in the OSD menus
- ⑪ Back: Return to previous menu
- ⑫ EXIT: Exit the menu
- ⑬ HOME: Enter the Home screen
- ⑭ VOL + / - : Adjust the volume
- ⑮ CH \wedge / \vee : Switch channel
- ⑯ MIC: Activate the microphone
- ⑰ SUBTITLE: Press to display the Subtitle Language menu
- ⑱ INFO: Display the present programme information
TEXT: Turn on/off the teletext function
- ⑲ MUTE: Mute or restore the TV sound
- ⑳ APP: Fast access to applications
MEDIA: Enter the media
: Fast access to all applications

NOTE: The included remote control will vary depending on models/countries/regions. Check information according to the actual remote control in the accessory bag.

Remote Control

Installing Batteries in the Remote Control

NOTE: Check information according to the actual remote control in the accessory bag.

1. Slide the back cover to open the battery compartment of the remote control.
2. Insert two AAA size batteries. Make sure to match the (+) and (-) ends of the batteries with the (+) and (-) ends indicated in the battery compartment.
3. Close the battery compartment with the cover.

1

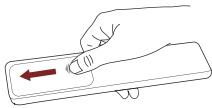

2

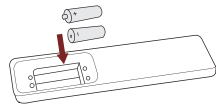

3

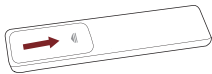

NOTE

- Product image is only for reference, and actual product may vary in appearance.

Handling the Batteries

- Incorrect use of batteries may cause corrosion or battery leakage, which could cause fire, personal injury or damage to property.
- Only use the battery type indicated in this manual.
- Do not mix old and new batteries or different types of batteries.
- Do not dispose of used batteries as domestic waste. Dispose of them in accordance with local regulations.
- Battery chemicals can cause a rash. If the batteries leak, clean the battery compartment with a cloth. If chemicals touch your skin, wash immediately.
- If you do not intend to use the remote control for a long time, remove the batteries.
- Remove depleted batteries immediately to prevent battery acid from leaking into the battery compartment.

Pairing the Remote Control

Pair the remote to the TV after you power it on. Keep the remote control within 3 metres from the TV. Press any button (except power and mic button) to pair.

NOTE

- In special cases, press and hold  button to pair.
- If an unknown error occurred with the remote, then it could have been caused by interference. Try to remove what's causing the interference and pair it again.
- If an unknown error occurred in the remote control while the battery power is normal, you can take out the batteries, press any key for 1~2 seconds, and insert them back. Then the remote control will work normally.
- The remote cannot be paired to the TV while the TV is in standby mode.

Remote Control Operation Range

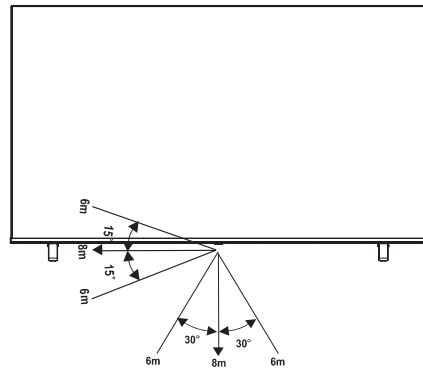

Turning the TV on for the First Time

1. Connect the mains cable to the mains socket after you have completed all the connections.
2. The first time you turn the TV on, it will go straight into the Installation Guide.
3. Press the / / / button to navigate the menu and change the settings. Press the button to confirm.

Select your Language

Select your desired language to be displayed on the menu.

Press menu button to set up your TV for store mode.

Connect to the Internet

If your TV does not automatically detect an Ethernet connection, then use a wireless network, select your network from the list that displays, also you can add a hidden network.

Select your Country

Select the Country where you will operate the TV.

Terms & Conditions, Privacy Policy

Your use of this device is subject to the End User License Agreement, and lack of your acceptance of the End User License Agreement will turn off all smart features of this device. Please read the details carefully before you choose.

Enhanced Viewing

Enhanced viewing can automatically adjust the picture mode and sound mode so as to match with the current content displayed on this device in case it is recognised by the automatic content recognition service.

Sign in your VIDAA Account

Link your TV with VIDAA account.

Name Your TV

Give your TV a name.

Select your Voice Assistant

Select your voice assistant you want to use on the TV.

NOTE

- The Guide above is for referencing purpose and may differ depending on models/countries/regions.

Channel Scan

You can scan for channels automatically or manually.

NOTE

- Satellite/antenna/cable function may not be applicable in some models/countries/regions.

Auto Scan

Automatically scan for channels to view programmes from TV source.

INPUT > TV

Alternatively, in Live TV, > **Settings** > **Channel** > **Auto Scan**.

If no TV channels were saved before, you will be prompted to do a channel search.

● Satellite

- **Single satellite:** You can use single satellite if you only have one satellite equipped.

- **DiSEqC:** You can choose DiSEqC if you have DiSEqC equipment. Up to four satellites in DiSEqC 1.0 mode can be installed.

If you are using a motorised antenna, you can use DiSEqC 1.2 mode.

- **Unicable:** If your house is equipped with Unicable satellite distribution, you should use this option.

Please make sure that you know the Unicable band and frequency that can be used. The information should be available on the equipment or the landlord can provide it.

● Antenna

- **Channel:** Select from **All Channels** or **Free Channels**. This option may not be available depending on countries/regions/operators.

- **Scan Mode:** Select from digital channels only (DTV), digital and analogue channels (DTV+ATV) or analogue channels only (ATV).

If you receive DVB-T or DVB-T2 signal, you can use DTV.

- **LCN:** Switch on/off LCN (Logical Channel Number).

Please note that some operators are restricted to manually change the channel order. If you switch off LCN, then the channel list can be edited after channel scan.

This function may not be applicable in some models/countries/regions.

● Cable

- **Channel:** Select from **All Channels** or **Free Channels**. This option may not be available depending on countries/regions/operators.

- **Scan Mode:** Select from digital channels only (DTV), digital and analogue channels (DTV+ATV) or analogue channels only (ATV).

- **LCN:** Switch on/off LCN (Logical Channel Number).

Please note that some operators are restricted to manually change the channel order. If you switch off LCN, then the channel list can be edited after channel scan.

This function may not be applicable in some models/countries/regions.

Manual Scan

Manually scan for channels to view programmes from your TV sources through DTV or ATV.

In Live TV, > **Settings** > **Channel** > **Advanced Settings** > **Manual Scan**

● DTV Manual Scan

Manually scan for DTV channels to view programmes from a TV source.

When the DTV Manual Scan screen appears, press / button to select **Antenna**, **Cable** or **Satellite**, and select **Start** to commence the search of that channel. When the signal has been tuned, signal strength will be displayed on the screen.

● ATV Manual Scan

Manually scan for ATV channels to view programmes from a TV source.

- **Frequency:** Input the channel frequency you want.

- **Picture System:** Select the Colour System.

- **Sound System:** Select the Sound System.

Live TV tutorial

After channel scanning is done for the first time, the screen will display Live TV operating tutorial, including:

/ : Load the info bar

/ : Load the channel list

: Open the electronic programme guide (only available in some models/countries/regions)

: Load on-screen menu

: Call up search function

: Jump to the previous channel

NOTE

- The remote control buttons may vary depending on models/countries/regions.

Channel List

Displaying the channel list

In Live TV, press the **OK** / **CHList** button to display the Channel List menu.

Alternatively, in Live TV, **Menu** > **Channel List**.

Entering the sub-menu of channel list

In Live TV, **OK** / **CHList** > **Right Arrow**

Introducing the sub-menu

In Live TV, **OK** / **CHList** > **Right Arrow**

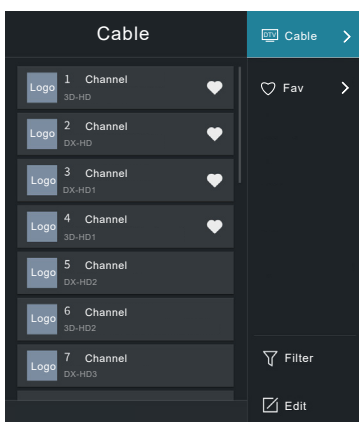

TV List

Display Live TV channel categories, such as **Cable** and **Antenna**.

Fav

Display favourite lists 1 to 4.

Filter

Select channels by **Content**, **HD**, **Child Lock**, **Scrambled** and **Sort**.

Some options in **Filter** may not be available in some models/countries/regions.

Edit

Edit the channel list.

NOTE

- The sub-menu options may vary depending on models/countries/regions.

Channel Edit

Manually edit the channel list to your preference.

Editing Live TV channels

In Live TV, press **OK** / **CHList** > **Right Arrow** to select a Live TV channel category such as Antenna or Cable, then use D-pad to select **Edit**.

Alternatively, in Live TV, press **Menu** button, select **Settings** > **Channel** > **Channel Edit**, and select a Live TV channel category such as Antenna or Cable.

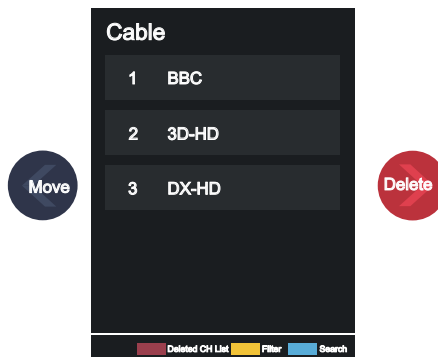

- Press **OK** button on the selected channel, then a checkbox will appear. You can select multiple channels at the same time to move or delete.
- Move: Press **Left Arrow** button to move the selected channel. Moving the channels could be restricted by the operator. If you want to be able to move channels, it is not recommended to choose an operator during channel scan, and LCN should be set to Off.
- Delete: Press **Right Arrow** button to delete the selected channel.
- Restore: Press **[RED]** button, or press **Color** button to call out the colour menu and select RED to enter the list of deleted channels. Press **Left Arrow** button to restore the deleted channel.
- Filter: Press **[YELLOW]** button or press **Color** button to call out the colour menu and select YELLOW, the filter screen will pop up. Press **OK** button to select options, and the channel list can be updated.
- Search: Press **[BLUE]** button or press **Color** button to call out the colour menu and select BLUE, to search the channel.

Exporting to USB

Allow you to export the current channel list to a USB storage device.

In Live TV, **Menu** > **Settings** > **Channel** > **Channel Edit** > **Export to USB**

Importing from USB

Allow you to import a previously exported channel list via a USB storage device.

In Live TV, **Menu** > **Settings** > **Channel** > **Channel Edit** > **Import from USB**

Favourite

Adding a channel to a favourite list

- 1 In Live TV, press **OK** / **CH.List** button to call out the channel list.
- 2 Press **≡** button and select the channel(s) you want to add to the favourite list.
- 3 Select **Add to Favourite**, and choose from **FAV1-FAV4**.
- 4 Then, a heart-shape icon will appear next to the added channel.

Viewing your favourite list

In Live TV, press **OK** / **CH.List** > **>** > **Fav** to call out the favourite list.

Editing the favourite list

In Live TV, press **OK** / **CH.List** > **>** > **Fav** > **>** to select **FAV1-FAV4**, then use D-pad to select **Edit**.

Alternatively, go to **≡** > **Settings** > **Channel** > **Channel Edit**, and select **FAV1 - FAV4**.

You can add, move or remove favourite channels.

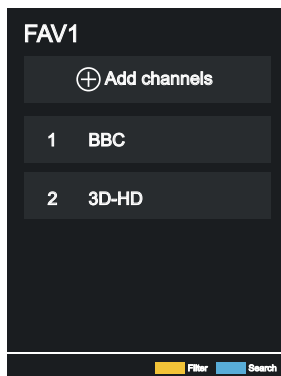

- Select **+ Add channels** to add the selected channel to the favourite list.
- Select a channel in a favourite list, and press **<** button to move it.
- Select a channel in a favourite list, and press **>** button to remove it.

NOTE

- These steps should be operated under the TV input.
- Before you edit the favourite lists, complete channel scan first.
- You can add channels from various reception types to the favourite list.

Guide (EPG)

The Guide (EPG) provides a convenient way to check TV programmes for the upcoming 7 days. The information displayed by the Guide (EPG) is made available by the commercial television networks for digital channels only. The Guide (EPG) also provides a simple way to record your favourite programmes and a reminder function which can switch channel automatically at scheduled time, so that you will not miss programmes of interest. The availability and amount of programme information will vary depending on the particular broadcaster.

NOTE

- The Guide (EPG) function is only available for digital channels. Analogue channels are not supported.

In Live TV, press **guide** button, or press **≡** > **Guide (EPG)** to display channel information on programme guide list.

● Watch

In Guide (EPG), when a current programme is selected, press **OK** > **Watch** to switch to the channel you want to see.

● PVR/Reminder

In Guide (EPG), press **▲** / **▼** button to select the channels. Press **<** / **>** button to select programme based on the time schedule. Press **OK** button to select **PVR** or **Reminder**.

NOTE

- Reminder in the Guide (EPG) is only available for programmes that haven't been aired yet.
- A storage device (space should be no less than 2G, and transfer rate should be no less than 4MB/s) must be attached to the TV for recording purposes. It is strongly recommended to use USB mobile hard disk drive instead of USB flash drive as the storage device.
- The TV will record the programme even in standby mode.
- The PVR function may not be applicable in certain models/countries/regions.

● Schedule

In Guide (EPG), press **[RED]** button or press **⦿** button to call out the colour menu and select **RED**, to view a list of scheduled reminders and recordings.

● Programme Colour

In Guide (EPG), press **[GREEN]** button or press **⦿** button to call out the colour menu and select **GREEN**, to choose colours to indicate different genres in the Guide (EPG) for quick and easy viewing.

(This function may not be applicable in certain countries/regions.)

● 24h-

In Guide (EPG), press **[YELLOW]** button or press **⦿** button to call out the colour menu and select **YELLOW**, to select programmes of the previous day.

● 24h+

In Guide (EPG), press **[BLUE]** button or press **⦿** button to call out the colour menu and select **BLUE**, to select programmes of the next day.



PVR

The PVR function allows you to easily record digital television content for later viewing. The function is only available for digital channels. To use PVR, you must connect a storage device for recording. The format of the storage disk should be NTFS, FAT32. The PVR will not function if a data storage device has not been connected.

Schedule Recording



In Live TV, press  > PVR.

Alternatively, press  /  to load the info bar, and select a programme and choose **PVR**.

If your remote has  button, press it and use D-pad to select  to set up PVR.

You can select recording mode from time, manual stop and program.

When you select time, you can set the appointment time and period.

In Guide (EPG), press the  [RED] button or press  button to call out the colour menu and select RED, to view the scheduled recording. In schedule recording list, you can readjust the reservation information that has been set.

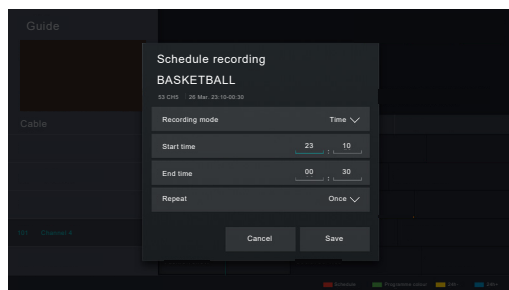

Standby Recording

If you press the power button during recording and select **Standby Recording**, your TV will go into standby mode but the recording process is still going on. If you press power button again to wake up the TV, the recording process will not be affected. After recording, the recorded file will be automatically saved to the disk.

NOTE

- The storage space of your device should be no less than 2G (for 15 minutes high definition video). It is strongly recommended to use USB mobile hard disk drive instead of USB flash drive as the storage device.
- If the transfer rate of your hard disk is too slow, a pop-up notice will appear. In this case, you can use another disk with higher speed.
- The PVR function doesn't support analogue channels.
- Some broadcasters may restrict to record the programme.
- During the recording progress, channels locked with Channel Lock (password needed) are disabled to watch.
- Some channel-related configuration may conflict with background recording. In this case, a reminding window will pop up.
- The PVR function may not be applicable in certain models/countries/regions.

Recording List

Accessing the recording list

View the list of recorded programmes and scheduled list.

To enter the recording list:

In Live TV,  > **Recording List**

Managing the recording list

In Live TV,  > **Recording List** > **Recorded**

You can watch, sort or delete recorded programmes.

● Watch recorded programme

Select a recorded programme in the recording list, and press  button to watch it.

● Sort recorded programme

Select **All**, and you can choose from the list to sort the recorded programme.

NOTE

- This function may not be applicable in some models/countries/regions.
- **Delete recorded programme**
Select **Edit**, select a recorded programme in the recording list, and press  button to delete it.

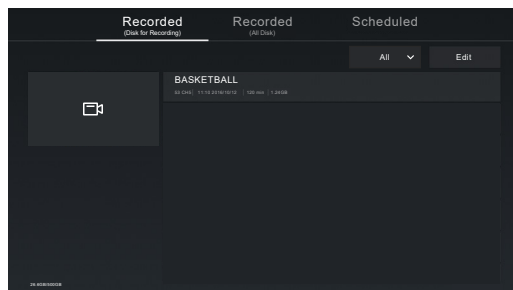

If you connect more than one storage devices to the TV, **Recorded (Disk for Recording)** and **Recorded (All Disk)** are available on-screen to select.

In **Recorded (Disk for Recording)**, you can watch recorded programme of the storage device that is selected at  > **Settings** > **System** > **Advanced Settings** > **PVR & Time Shift** > **PVR Setup/Time Shift Setup**.

● Managing the schedule list

In Live TV,  > **Recording List** > **Scheduled**

You can change scheduled recording information and reminder information, or cancel scheduled recordings or reminders.

● Delete scheduled recording or reminder

Select **Edit**, select a scheduled recording or reminder in the schedule list, and press  button to delete it.

● Edit scheduled recording or reminder

Select scheduled recording or reminder in the schedule list, and press  button to adjust it.

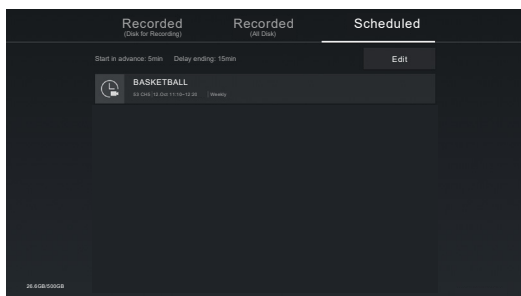

NOTE

- The Recording List function may not be applicable in some models/countries/regions.

Timeshift

This option allows you to pause and rewind Live TV. This function operates by recording temporarily to a storage device. Please ensure your storage device is connected and there is enough free disk space. Otherwise, the timeshift function will not commence.

In Live TV, press **Menu** > **Timeshift**, and then the playback bar will appear. If your remote has **Pause** button, press it and press **OK** button to launch Timeshift.

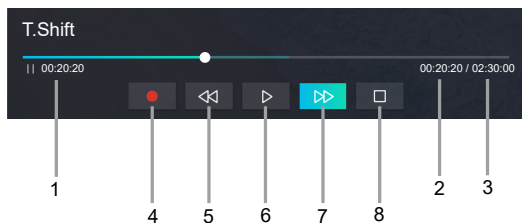

- Unwatched time for buffered content
- Current time
- Total time
- Record**: to convert timeshift to live recording of current broadcast channel. Select **Record** and the programme content you've watched in Timeshift before will also be saved in the storage device.
- Fast backward**: you can choose 2x, 4x, 8x or 16x.
- Pause/Play**
- Fast forward**: you can choose 2x, 4x, 8x or 16x.
- Stop Timeshift**: to exit the function and watch the current broadcast.

NOTE

- The Timeshift function doesn't support analogue channels.
- The storage space of the device should be no less than 2G. It is strongly recommended to use USB mobile hard disk drive instead of USB flash drive as the storage device.
- The Timeshift function may not be applicable in some models/countries/regions.

Multi-screen

Screen Sharing

Mirror your mobile device screen to the TV.

Before using Screen Sharing, please set your TV to the wireless network connection.

INPUT > Screen Sharing

- 1 Turn on the casting function of your Android/Windows10 device. The setting icon may vary depending on the device. The feature may be called "Wireless display", "Smartview", "Wireless projection", etc.
- 2 Find the TV name in the searching list of your device and select it. Wait for the connection progress to complete and the content on your device will be displayed on the TV.

NOTE

Some mobile devices may not support casting.

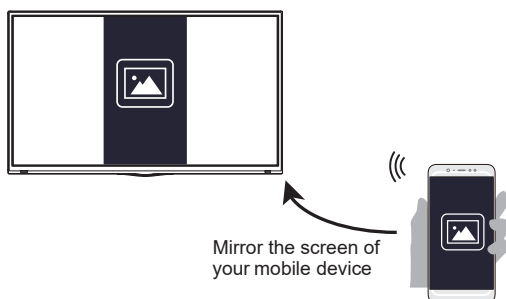

Content Sharing

Content Sharing allows you to view media content, like videos, music or photos saved in your Android/iOS/PC device on your TV screen.

Sharing media content from your Android/iOS/PC device

- 1 Connect your TV and Android/iOS/PC device to the same network.
- 2 Turn on Content Sharing at **Home** > **Settings** > **System** > **Application Settings** > **Content Sharing**.
- 3 Turn on the content sharing function in your Android/iOS/PC device.
- 4 Find the TV name in the searching list of your device and select it. Wait for the connection progress to complete.
- 5 In your Android/iOS/PC device, choose the media content you want to share on your TV.



Playing media content from your Android/iOS/PC device on the TV

You can connect media content saved in your Android/iOS/PC device to your local network and play the content on your TV.

- 1 Connect your TV and Android/iOS/PC device to the same network.
- 2 Turn on Content Sharing at **Home** > **Settings** > **System** > **Application Settings** > **Content Sharing**.
- 3 Make sure your media content in your Android/iOS/PC device are visible through local network.
- 4 On your TV, select a device with media content at **Home** > **Input**, or **Home** > **My Apps** > **Media**.
The media content list in your Android/iOS/PC device appears.
- 5 Select a media content item from the list to play.

NOTE

- Some Android/iOS/PC devices may not support content sharing function. If your device doesn't support content sharing, you can download an app that supports the function to connect to your TV.
- The content may not be played depending on the file format.
- The content may not be played smoothly or the function may not work properly due to the network condition.

Smart Functions

Getting Familiar with the Home Screen

Press  button on your remote control to enter the Home screen. The Home screen serves as the central location to run the TV more conveniently.

To exit the Home screen, press **INPUT** button on your remote or use the navigation buttons to move the cursor to the  **Input** icon on the top of the screen, press **OK** button to enter, and select your desired input source.

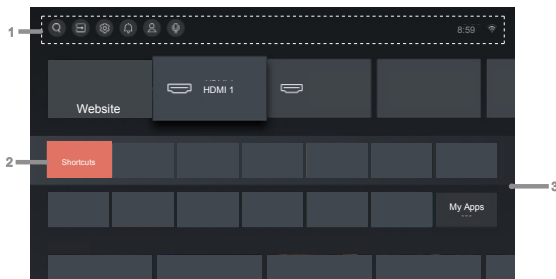

- 1 Navigation bar
- 2 Shortcuts
- 3 Apps

Using the navigation bar

The navigation bar refers to indicators and icons on the top of the Home screen.

NOTE

- Indicators or icons may vary depending on models/countries/regions.

Search

Search the content you want.

Input

Select the Input source depending on the device you have connected to your TV.

Settings

Let you configure the TV.

Notifications

Allow pop-up notifications to appear for useful information and events that occur with your TV, including: **Advertising, New Arrivals, Warnings and Legal Statements, System Messages and Alexa Notification**. You can enable/disable each of these notifications at Settings in the notification centre.

You can view the list of event messages generated by the TV.

To delete all notifications, select **Clear All**.

NOTE

- The Alexa Notification may not be applicable in some models/countries/regions.
- When you sign in your VIDAA account, please find Notifications in VIDAA Account on the Home screen.

VIDAA Account

Sign in your VIDAA account.

A VIDAA account gives you all the best features of your smart TV and always keeps it up to date.



Voice

Quick access to **Voice Service**.

Time

You can always view the current time at the top of the Home screen.

Network

Connect your TV to the Internet through a wireless connection  or an Ethernet cable , and the corresponding icon will appear.

Using the Shortcuts

You can add inputs, channels and websites to the Home screen to have quick access to them for your convenience.



Add inputs to the home screen

- 1 Press **INPUT** button.
- 2 Move the focus to an input you want to add to the Home screen, and press  > **Add to home** > **OK**. The input icon will appear in Shortcuts on the Home screen.

NOTE

- Some options in inputs source page cannot be added to the Home screen.
- To remove inputs from Shortcuts, just move the focus to a shortcut page and press  button on your remote control.

Add channels to the home screen

- 1 In Live TV, press **OK** /  button to access the channel list.
- 2 Press  button and press **OK** button to tick channel(s) that you'd like to add on the Home screen.
- 3 Select **Add to home**. The channel icon will appear in Shortcuts on the Home screen.

NOTE

- To remove channels from Shortcuts, just move the focus to a shortcut page and press  button on your remote control.

Add webpages to the home screen

- 1 In Browser, visit a website you'd like to add on the Home screen.
- 2 Use the D-pad to move the focus to  **Add to home** icon in the top Browser navigation bar and select it.
- 3 Select **Add**, and this webpage will appear in Shortcuts on the Home screen.

NOTE

- To remove webpages from Shortcuts, just move the focus on a shortcut page and press  button on your remote control.

Smart Functions

Managing apps

> My Apps

Select the item you want to move, press button to manage, and press button to store position.

NOTE

- Some app may not be moved.

Using a VIDAA Account

Signing into an account

Before signing into your VIDAA account, make sure your TV is connected to network.

- After the network is connected, press button on your remote and select VIDAA Account icon in the top navigation bar on the Home screen.
- Register your device to your VIDAA Account. After entering your email and password, select **Sign In**.

Creating a new account

If you don't have a VIDAA account, create a new one to enjoy best features of your smart TV.

Before creating a new account, make sure your TV is connected to network.

- After the network is connected, press button on your remote and select VIDAA Account icon in the top navigation bar on the Home screen.
- Select **Create an Account** on screen.
- Enter your first name, last name, email address and password. First Name and Last Name are optional.
- Select **Create an Account**.

Using Voice Service

To access the Voice Service, press button on your remote and select Voice icon in the navigation bar. Alternatively, just press button on your remote.

NOTE

- Voice Service feature may not be applicable in some models/countries/regions.
- To use this function, End User License Agreement and corresponding smart feature privacy policy/terms and conditions may be required to agree.

Alexa

Interact with Alexa by pressing and holding the microphone button on your remote. You can ask Alexa to control this TV.

Before setting up Amazon Alexa Service, connect your TV to the network and sign in your VIDAA Account at > VIDAA Account.

How to set up Alexa

- Press button to select Settings icon, and select **System > Voice Service > Amazon Alexa**.
- Select **Set voice assistant to Alexa** and **Set up now**. If you have selected Alexa in the Guide when you turn on the TV for the first time, it will directly guide you to the **Set up now** step.
- Now, you are in the step 'Sign in to Amazon Account'. Scan the QR code with your phone, or visit the website on your phone or computer, and enter the on-screen code. The code will be expired after 10 minutes. If you don't have an Amazon account, create a new one.
- After you connect the Amazon account, the TV screen changes into the next step. You can sign into your VIDAA account. If you have signed in before, this step will be skipped.
- Give your TV a name from the list, or you can customise it.
- Select **Authorise** and follow on-screen steps in Alexa Skill Setup settings.

Now, Alexa is set up and ready. You can enjoy interacting with Alexa using your voice by just pressing and holding the button on your remote control. Ask Alexa after the tone.

NOTE

- The Alexa function may not be applicable in some models/countries/regions.
- The setup steps above may vary. Please refer to the actual product.
- Shipment with voice remote control varies depending on TV models/countries/regions.
- You can use Alexa without signing in your account by selecting **Do it later**. In this case, you can still use your voice to change the channel and control playback. Sign in your account in the setting in anytime to enjoy more functions of Alexa.
- This feature requires Alexa built-in service. Otherwise, use external Alexa-enabled devices (e.g. Alexa App, Echo) to control your smart TV by using just your voice.
- Download and install remote control app on your mobile device at > Settings > **Support > Mobile App Download**. Press the microphone icon in the app to interact with Alexa on your TV.
- You can select the language used by Alexa at > Settings > **System > Voice Service > Amazon Alexa > Alexa Language**. This feature requires Alexa built-in service, which varies depending on TV models and countries/regions.

Hands-free Wake-up

Interacting with Alexa by just using your voice, all hands-free.

Before using hands-free wake-up, connect your TV to the network and sign in your VIDAA Account at > VIDAA Account.

How to use Hands-free Wake-up

- Turn on the built-in microphone on the TV.
- Press button to select Settings icon, and select **System > Voice Service > Amazon Alexa**.
- Select **Set voice assistant to Alexa** and **Set up now**. If you have selected Alexa in the Guide when you turn on the TV for the first time, it will directly guide you to the **Set up now** step.

Smart Functions

- 4 Select **Built-in Microphone**. And you can select **Wake up TV by voice** at the same time. When **Wake up TV by voice** is turned on, you can wake up the TV from standby mode by just saying "Alexa". Turn on **Wake up TV by voice** function will increase energy consuming.
- 5 Now, you are in the step 'Sign in to Amazon Account'. Scan the QR code with your phone, or visit the website on your phone or computer, and enter the on-screen code. The code will be expired after 10 minutes. If you don't have an Amazon account, create a new one.
- 6 After you connect the Amazon account, the TV screen changes into the next step. You can sign into your VIDAA account. If you have signed in before, this step will be skipped.
- 7 Give your TV a name from the list, or you can customise it.
- 8 Select **Authorise** and follow on-screen steps in Alexa Skill Setup settings. Now, Hands-free Wake-up is set up and ready. Speak to the TV and just say "Alexa", then you can wake up Alexa in this TV.

NOTE



- The Hands-free Wake-up function may not be applicable in some models/countries/regions.
- Built-in microphone may not be available in some models.
- The setup steps may vary. Please refer to the actual product.
- This feature requires Alexa built-in service.

Google Assistant

Setup Google Assistant, and enjoy Google Assistant service. You can ask for information, search for your favourite movies, control your TV and more, just by asking Google Assistant.

Before setting up Google Assistant, connect your TV to the network.

STEP 1: Set up Google Assistant on TV

- 1 Press  button on your remote to select  **Settings** icon, and select **System > Voice Service > Google Assistant**.
- 2 Set voice assistant to Google Assistant and press  button to set up. If you have selected Google Assistant in the Guide when you turn on the TV for the first time, it will directly guide you to the set up step.
- 3 Then, read on-screen terms of service and privacy policy, and select **I understand**.
- 4 Next, select **Allow** to enable information sharing.

STEP 2: Set up in Google Assistant app

Follow the setup instructions on-screen to set up Google Assistant.

- 1 Download and install the Google Assistant app on your mobile device, and open the app.
- 2 Speak to Google Assistant app, "Set up my Assistant device", and follow the instruction in the app to set up Google Assistant and sign in your Google account to this TV.

Google Assistant is set up and ready. Control your smart TV using your voice by just pressing and holding the  button on your remote control.



NOTE

- The Google Assistant function may not be applicable in some models/countries/regions.



- The setup steps above may vary. Please refer to the actual product.
- Shipment with voice remote control varies depending on TV models/countries/regions.
- If you don't choose to set up Google Assistant in the mobile app, just press  button to continue without signing in your Google account. You can go to TV system settings later to sign in your Google account to enjoy personal queries by asking Google Assistant, like showing your photos, calendar and more on this device.

Google Smart Home Service

For some models or when you use the TV in certain countries/regions, Google Smart Home Service function is available. Set up Google Smart Home Service to control your smart TV with Google Home devices or app. You can change channels or inputs, adjust volume and more.

Before setting up Google Smart Home Service, connect your TV to the network and sign in your VIDAA Account at  >  **VIDAA Account**.

STEP 1: Set up Google Smart Home Service on TV

- 1 Press  button on your remote to select  **Settings** icon, and select **System > Voice Service > Google Smart Home Service**. Select **Set up now**.
- 2 Sign into your VIDAA account. If you have signed in before, this step will be skipped.
- 3 Give your TV a name.

STEP 2: Set up in Google Home app

Follow the setup instructions on-screen to set up Google Smart Home Service.

- 1 Download and install the Google Home app on your mobile device, and open the app.
- 2 Find and select VIDAA Voice service in the app.
- 3 Follow the instructions in the app to link your VIDAA account signed in on your TV to your Google Account.



Google Smart Home Service is set up and ready. Control your smart TV by using your voice through Google Home device or app.

NOTE

- Google Smart Home Service may not be applicable in some models/countries/regions.
- The setup steps above may vary. Please refer to the actual product.

Yandex Smart Home Service

Yandex Alice voice assistant can obey certain commands to help you change the TV's configuration.

Before setting up Yandex Smart Home Service, connect your TV to the network and sign into your VIDAA Account at  >  **VIDAA Account**.

Smart Functions

STEP 1: Set up Yandex on TV

- 1 Press button on your remote to select **Settings** icon, and select **System > Voice Service > Yandex**.
Select **Set up now**.
- 2 Sign into your VIDAA account. If you have signed in before, this step will be skipped.
- 3 Give your TV a name.

STEP 2: Set up in Yandex App

Follow the instruction on TV to enable Yandex Smart Home Service.

- 1 Download Yandex app on your mobile device.
- 2 Open the app and sign in your Yandex account.
- 3 In the Yandex app, go to "Devices" > "Smart Home", click add device icon, and select "VIDAA Voice".
- 4 Perform account linking using the same VIDAA account signed in on your TV.

Yandex Smart Home Service is set up and ready. Now you can control your smart TV with Yandex Alice devices or Yandex app to change channel, change inputs, adjust volume and more, just by asking Alice.

NOTE

- The Yandex function may not be applicable in some models/countries/regions.
- The setup steps above may vary. Please refer to the actual product.

VIDAA Voice

VIDAA Voice is a voice assistant to help you control the TV and search content, supporting several languages.

Before using VIDAA Voice, please check the following:

- Network connected
- Voice remote paired
- End User License Agreement and voice feature privacy policy/terms agreed

To access the Voice Service centre and set voice assistant to VIDAA Voice, you can choose one of following options:

- Just press the Microphone button on your remote.
- Press button on your remote and select **Voice** icon in the navigation bar.
- Press button to select **Settings** icon and select **System > Voice Service**.

When VIDAA Voice is selected as your voice assistant, select the language of VIDAA Voice in Voice Service centre. Then, press and hold the Microphone button on your remote to interact with VIDAA Voice.

NOTE

- VIDAA Voice may not be applicable in some models/countries/regions.

Voice service other issues

If you want to turn on your TV with Alexa-enabled devices (e.g. Echo, Echo show) or Google Home devices (e.g. Google Home, Google Nest Hub), please:

- 1 Turn on **Wake on LAN** and **Wake on Wireless Network** at >

Settings > Network.

- 2 Make sure your TV and Alexa-enabled devices/Google Home devices are connected to the same network environment.

NOTE

- Only Alexa (Alexa skill is enabled) and Google Smart Home Service support turning on your TV with Alexa Echo or Google Home. Google Assistant (built-in) doesn't support this function.

Media

> **My Apps > Media**

Media is a central location for you to view or listen to different types of content, such as photos, music and movies. You can view media content through the following methods:

- A USB thumb drive or hard drive.
- Compatible mobile phone, tablet or other personal devices: you can stream movies, music and photos that are stored on compatible personal device and play or view the content on your TV.

By default, there is **Content Sharing** displayed on the Media screen. If your mobile device is connected to the TV, its name also appears on the Media screen.

Playing media contents

> **My Apps > Media > connected devices**

Select the content you want to play on the screen, like pictures, videos and music.

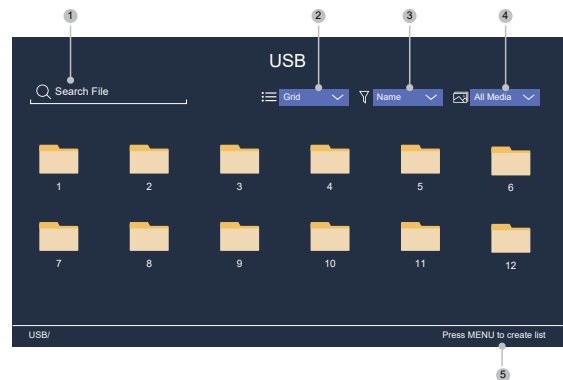

- 1 Search the content you want to play.
- 2 Arrange the content list by **Grid, List**.
- 3 Sort the content list by **Name, Date modified, Size**.
- 4 Filter the content list by **All Media, Photo, Video, Music, Recorded**.
- 5 Create a photo, music, or video playlist.

NOTE

- Some options in the above table may not be available in some models/countries/regions.

Playing background music during viewing pictures

- 1 Choose a picture to display.

Smart Functions

- Press button to call out playbar.
- Select **Background Music** and choose your music to create a Music Playlist.

Now you can play the background music during viewing pictures.

Media format list

Due to differences in programming tools and other factors, some of the file formats that are listed may not be supported.

Video Format

Container	Video Codec	File Extension Name	Resolution and Frame Rate
MPG	MPEG-2	.mpg .mpeg	1920 x 1080p @ 120fps
MPEG	MPEG-2		
MP4	MPEG4	.mp4	1920 x 1080p @ 120fps
	H.264(AVC)		3840 x 2160p @ 30fps
	H.265(HEVC)		3840 x 2160p @ 60fps
	AV1		3840 x 2160p @ 60fps
MOV	MPEG4	.mov	1920 x 1080p @ 120fps
	H.264(AVC)		3840 x 2160p @ 30fps
	H.265(HEVC)		3840 x 2160p @ 60fps
MKV	Mpeg2,4	.mkv	1920 x 1080p @ 120fps
	H.264(AVC)		3840 x 2160p @ 30fps
	H.265(HEVC)		3840 x 2160p @ 60fps
	AV1		3840 x 2160p @ 60fps
AVI	Mpeg2,4	.avi	1920 x 1080p @ 120fps
	H.264(AVC)		3840 x 2160p @ 30fps
FLV	H.264(AVC)	.flv	3840 x 2160p @ 30fps
	H.265(HEVC)		3840 x 2160p @ 60fps
WEBM	VP8	.webm	1920 x 1080p @ 120fps
	VP9		3840 x 2160p @ 60fps
	AV1		3840 x 2160p @ 60fps

Audio Format

Container	Audio Codec	File Extension Name
WAV	LPCM	.wav
	ADPCM	
MP3	Mpeg1-Layer3	.mp3
	Mpeg2-Layer3	
	Mpeg2.5-Layer3	
AAC	AAC-LC	.m4a .aac
	HE-AAC(v1/v2)	
WMA	WMA	.wma
	WMA Pro	
FLAC	FLAC	.flac

Photo Format

Container	File Extension Name	Mode of Operation	Resolution
JPEG	.jpg .jpeg	-	7680 x 4320
PNG	.png	no-interlace interlace	
BMP	.bmp	-	
GIF	.gif	-	
TIF	.tiff	-	

NOTE

- You must obtain any required permission from copyright owners to download or use copyrighted content. TOSHIBA cannot and does not grant such permission.

App

> My Apps

Numerous factory-installed apps are available for you to choose for your entertainment preferences.

Installing an app

Even though your TV has numerous factory-installed apps, there may be others that you'd like to download.

To install an app:

- > **My Apps** > **APP STORE**.
- Use the navigation buttons on your remote to select the app that you want to install.
- Select **Install**. The selected app is installed on the TV.

NOTE

- To use this function, your TV must be connected to the Internet.
- Adding apps is free, but it might cost you money when using some apps.

Sorting apps in My Apps

- In **My Apps** select the app you want to sort, and then press button to select **Sort**.
- Press button to move it.
- Press button to store position.

NOTE

- Some app may not be moved.

Removing an app in My Apps

You can only delete apps that you've installed to the TV. Factory-installed apps can not be deleted.

- In **My Apps** select the app you want to remove, and then press button to select **Remove**.
- Select **OK**. The selected app is deleted.

Installing Mobile App to Control your TV

Press button to select **Settings** icon, and select **Support** > **Mobile App Download**.

You can scan the Mobile App download QR code on screen to install the app on your mobile to control your TV, such as turning the TV on or off, typing in with your mobile's keyboard, and sharing pictures or videos from your mobile to TV. This app is available on both Android and iOS.

To connect your TV after installing the mobile app:

- Agree with end user license, and disclaimer and privacy policies on TV. If you are not sure whether you have agreed, check at > **Settings** > **Support** > **Disclaimer and Privacy**.
- Make sure your mobile phone and TV are connected to the same network environment.
- To use this function, switch on **Content Sharing** at > **Settings** > **System** > **Application Settings** > **Content Sharing**.
- Open the mobile app and select the TV device you want to connect.

Picture and Sound

Adjusting the Picture Quality

Adjust picture mode, picture size and other advanced picture settings.

Choosing a picture mode

 >  **Settings** > **Picture** > **Picture Mode**

Select a preset picture mode to best suit the content you're viewing. Options may differ depending on models. Please refer to the actual product.

● **Standard**

Best suited for watching normal content, such as News, Drama or Documentary.

● **Cinema Day**

Best suited for watching movies in a bright environment.

● **Cinema Night**

Best suited for watching movies with dark environment.

● **Dynamic**

Best suited for the content that requires vivid picture quality.



● **Sports**

Optimised picture for watching sports.

● **Auto**

The picture mode will be adjusted automatically.

NOTE

- Auto mode may not be applicable in some models/countries/regions, and to use this function, you must choose **Yes, Enable Enhanced Viewing** in the Enhanced Viewing when you turn the TV on for the first time, or at  >  **Settings** > **System** > **Advanced Settings** > **Enhanced Viewing**.

Changing the aspect ratio

 >  **Settings** > **Picture** > **Aspect Ratio**

Adjust the Aspect Ratio to stretch or zoom in on your picture.

● **Automatic**

Automatically switch Aspect Ratio between 16:9 and 4:3 based on the signal information.

● **16:9**

Best suited for 16:9 Widescreen content. This will also stretch 4:3 content to Widescreen.

● **4:3**

Best suited for 4:3 content.

● **Panoramic**

Provide a full-screen image by stretching the edges whilst leaving the middle untouched.

● **Movie Zoom**

Provide a full-screen image by zooming in on the movie.

● **Direct**

Point to point display also known as 1:1 Pixel Mapping.

NOTE

- Using the special functions to change the size of the displayed image (e.g. changing the height/width ratio) for the purpose of public display or commercial gain may infringe on copyright laws.
- If the aspect ratio of the selected format is different from the one of the TV transmission or video programme, it can cause a difference in vision.
- When using PC connected via HDMI terminal, the moving image quality may be deteriorated.

Enabling Smart Scene function

 >  **Settings** > **Picture** > **Smart Scene**

You can turn on the Smart Scene function, and enable your TV to continually recognise the scene in the content watching and enhance the picture quality on all input sources.

NOTE

- Some specific application has explicit constraints that the content recognition is not allowed.
- When **Game Mode** is turned on, **Smart Scene** will be switched off automatically and is not available to set.

Configuring advanced picture settings

 >  **Settings** > **Picture** > **Picture Mode Settings**

Adjust display settings for each Picture Mode. You can personalise the picture quality by adjusting the following settings.

● **Apply Picture Settings**

Adjust current picture mode to apply to all sources or just current source.

● **Backlight**

Set the overall brightness of the screen.

NOTE

- The function name may vary depending on models.

The following option may differ depending on models. Please refer to the actual product.

Dynamic Backlight Control

Enhance the contrast ratio between light and dark areas of the picture.

This function may not be applicable in some models/countries/regions.

Backlight

Adjust how bright you want images to appear, lower settings create darker images (only when **Dynamic Backlight Control** is off).

This function may not be applicable in some models/countries/regions.

Automatic Light Sensor

Enable the TV to automatically adjust the picture settings according to the amount of ambient light in your room.

This function may not be applicable in some models/countries/regions.

Light Sensor Shift

This feature is adjustable only when Automatic Light Sensor is turned on. If you feel the picture is brighter than you expect, decrease the value. If you feel the picture is darker than you expect, increase the value.

This function may not be applicable in some models/countries/regions.

Local Dimming (or **Peak Brightness Dynamic Range** for some models)

Picture and Sound

Enable the TV to automatically adjust the backlight by sections according to the changes in the image and increase the contrast. This function may not be applicable in some models/countries/regions.

- **Brightness**

Adjust the Brightness level to generate lighter or darker images.

- **Contrast**

Adjust the Contrast level to increase or decrease how bright images appear.

- **Colour Saturation**

Adjust the colour intensity of the picture for a more vibrant image.

- **Sharpness**

Adjust how sharp or soft edges of images appear.

- **Adaptive Contrast**

Automatically darken dark areas and lighten light areas of images to see more details.

- **Ultra Smooth Motion**

Reduce seeing afterimages that are left on the screen when viewing fastmoving objects. This function may not be applicable in some models/countries/regions.

- **Clear Motion**

Making motion look clearer when flicker is desired. This function may not be applicable in some models/countries/regions.

- **Noise Reduction**

Improve how clear the picture appears by reducing noise.

- **MPEG Noise Reduction**

Reduce MPEG block noise and provide clearer edge transitions.

- **Colour Temperature**

Adjust how warm (red) or cool (blue) the white areas of an image appears.

- **Expert Settings**

Adjust advanced picture settings based on your viewing preference.

- **Overscan**

Change the video size settings to slightly crop the edges of the displayed image. This function may not be applicable in some models/countries/regions.

- **Reset Current Mode**

Restore all the picture settings in the current picture mode to the factory default values.

- **White Balance**

Adjust the intensity of red, green and blue lights to view the true colours of all images in the picture.

- **Black Level**

Adjust the HDMI signal range to be more suitable for the content.

- **Gamma Adjustment**

Adjust the Gamma to alter how the TV will respond to the grayscale content. In a dark room choose a higher number like 2.4. In a brighter area select a lower number like 2.0. In general, 2.2 is normally recommended.

This function may not be applicable in some models/countries/regions.

- **Gamma Calibration**

Adjust selected Gamma curve.

This function may not be applicable in some models/countries/regions.

- **Viewing Angle**

Provide better watching experience with viewing angel.

This function is only available in VAC-supported models.

- **RGB Only Mode**

View images based on default settings or choose the colour red, blue or green.

- **Low Blue Light**

Eyes care: reduce the emission of blue light.

This function may not be applicable in some models/countries/regions.

Configuring expert settings

 >  **Settings** > **Picture** > **Picture Mode Settings** > **Expert Settings**

Adjust the colour space and Gamma to best suit the content you're viewing.

- **Colour Gamut**

Change the range of colours the TV displays.

This function may not be applicable in some models/countries/regions.

- **Colour Tuner**

Adjust the Hue, Saturation and Brightness of colour settings.

Picture and Sound

Game Mode Settings

Enabling game mode

 >  **Settings** > **Picture** > **Game Mode**

You can turn the **Game Mode** on to optimise the TV's settings for you to enjoy a comfortable gaming experience with PC or game console connected to the TV.

In the Game Mode:

- Reducing input lag to make sure every press or click matches what's happening on the screen;
- Improving responsiveness to produce very little motion blur;
- Processing YUV 4:4:4 format signals precisely to present accurate image colours.

NOTE

- This function may not be applicable in some input sources or applications.

Enabling auto low latency mode

 >  **Settings** > **Picture** > **Auto Low Latency Mode**

You can enjoy a smooth viewing experience with external devices connected to the TV when **Auto Low Latency Mode** is turned on.

NOTE

- This function may not be applicable in some input sources or applications.
- When **Game Mode** is turned on, **Auto Low Latency Mode** will be switched off automatically and is not available to set.

Adjusting the Sound Quality

Adjust sound mode and other advanced sound settings.

Choosing a sound mode

 >  **Settings** > **Sound** > **Sound Mode**

Select a preset sound mode to suit the type of content you are listening to.

● **Standard**

In Standard mode, the TV delivers a flat frequency response, which preserves the natural characteristics of the original sound.

● **Theatre**

Theatre mode increases the surround sound effect and provides a more prominent subwoofer response.

● **Music**

In Music mode, low and high frequencies are emphasised to enhance musical instrument reproduction.

● **Speech**

In Speech mode, low and high frequencies are attenuated to improve the reproduction and clarity of the human voice.

● **Late Night**

In Late Night mode, the TV will improve the reproduction and clarity of the human voice with a low volume level.



● **Sports**

Optimised sound for watching sports programmes.

● **Auto**

The sound mode will be adjusted automatically.

NOTE

- Auto mode may not be applicable in some models/countries/regions, and to use this function, you must choose **Yes, Enable Enhanced Viewing** in the Enhanced Viewing when you turn the TV on for the first time, or at  >  **Settings** > **System** > **Advanced Settings** > **Enhanced Viewing**.

Dolby Atmos

 >  **Settings** > **Sound** > **Dolby Atmos**

Set **Dolby Atmos** to **On** to enhance the richness of sound, and you can enjoy an immersive listening experience.

This function may not be applicable in some models/countries/regions.

Audio Enhancement

 >  **Settings** > **Sound** > **Audio Enhancement**

Set **Audio Enhancement** to have audio experience provided by Dolby Atmos or DTS Virtual X according to your preference.

This function may not be applicable in some models/countries/regions.

Configuring advanced sound settings

 >  **Settings** > **Sound** > **Sound Mode Settings**

Tune the audio settings of the TV. You can personalise the sound quality by adjusting the following settings.

● **Apply Audio Settings**

Adjust current sound mode to apply to all sources or just the current source.

● **Total Sonics**

Optimise overall sound quality by increasing bass, making dialogue clear and natural, and widening the sound field.

This function may not be applicable in some models/countries/regions.

● **Total Volume**

Maintain consistent loudness levels from wide dynamic range programmes, loud commercials, and channel or input changes.

This function may not be applicable in some models/countries/regions.

● **Total Surround**

Provide surround sound experience with psycho-acoustic processing to place sounds beside, behind, and above the viewer. For best results use with Total Sonics.

This function may not be applicable in some models/countries/regions.

● **Bass Boost**

Bass Boost uses DTS TruBass™ to enhance the perception of bass frequencies to provide deep, rich bass response from the TV's internal speakers.

This function may not be applicable in some models/countries/regions.

● **Surround Sound**

Surround sound uses DTS TruSurround™ to deliver an immersive surround sound experience from the TV's internal speakers.

This function may not be applicable in some models/countries/regions.

Picture and Sound

● Dialogue Clarity

Dialogue Clarity uses DTS Dialogue Clarity™ to boost the frequency range of the human voice so dialogue is clearly understood and heard above audio or surround effects.

This function may not be applicable in certain models/countries/regions.

● TruVolume

Automatic control over drastic volume changes while watching TV programs or films, providing a more comfortable and consistent volume. This function may not be applicable in some models/countries/regions.

● Equalizer

Boost the volume at different frequencies.

This function is only applicable when **TV Speakers** is selected at  >

 **Settings > Sound > Speakers > Audio Output.**

● Subwoofer

Built-in subwoofer switch.

This function may not be applicable in some models/countries/regions.

● Bass Boost Value

Built-in bass adjustment.

This function may not be applicable in some models/countries/regions.

● Wall Mount Setup

Automatically optimise the sound based on the position of the TV. This function may not be applicable in certain models/countries/regions.

● Auto Volume Control

Activate to prevent the volume from changing when you switch TV channels.

This function may not be applicable in certain models/countries/regions.

● Reset Current Mode

Restore all of the audio settings in the current sound mode to the factory default values.

📌 NOTE

- Some models may not support decoding of DTS CD bitstreams. Playback of this format may produce undesirable noise.

Speakers Settings

 >  **Settings > Sound > Speakers**

Select the speakers which you want to use.

Audio Output



Select the speakers which you want to use.

Digital Audio Output

Select the digital audio output format that best suits the audio device type.

- **Auto:** the audio device automatically outputs in a supported format.
- **Pass Through:** the audio device outputs without any processing.
- **PCM:** the audio device outputs PCM (pulse code modulation) format.
- **Dolby Digital:** the audio device outputs Dolby Digital audio when connected to the TV via optical port.
- **Dolby Digital Plus:** the audio device outputs Dolby Digital Plus audio when connected to the TV via HDMI (ARC/eARC) port.

📌 NOTE

- This function is only applicable when  >  **Settings > Sound > Speakers > Audio Output** is set to **ARC** or **SPDIF Only**.
- When external audio devices are connected to the TV via optical, **PCM** and **Dolby Digital** are suggested.

Digital Audio Delay

Adjust the digital audio output delay time to sync sound from an external speaker with the images on the TV.

This function is only applicable when  >  **Settings > Sound >**

Speakers > Audio Output is set to **ARC** or **SPDIF Only**.

Lip Sync



Synchronise the displayed image with the audio output.

This function may not be applicable in some Audio Output modes.

Balance

Adjust the left and right speaker strength to optimise audio for a specific location. This function may not be applicable in some Audio Output modes. This function is not applicable when **Dolby Atmos** is turned on.

eARC

Connect an audio device that supports eARC via HDMI (eARC), and set **eARC** to **On** to enjoy higher sound quality. This feature is available to set when  >  **Settings > Sound > Speakers > Audio Output** is set to **ARC**.

This function may not be applicable in some models/countries/regions.

Using Headphones

 >  **Settings > Sound > Headphone**

Set the sound output mode through headphones.

After connecting your wireline or Bluetooth headphone, or other external audio amplifiers, you can set up your TV to your preference.

This function may not be applicable in some models/countries/regions.

Headphone Mode

Change the way audio is sent through the type of device that's connected to your TV Audio Out port.

When you select **Headphone Only**, disable the TV speaker when you are using a headphone, a sound bar, ARC or any other external audio amplifiers. Only external devices have audio output.

When you select **Headphone with Speakers**, TV speaker and Headphone or other connected external devices have audio output.

Headphone Volume

Independently adjust the volume of audio out devices.

In **Headphone Only** mode, you can adjust the volume with volume button on your remote or in Headphone Volume menu on screen.

In **Headphone with Speakers** mode, the TV speaker volume can be adjusted with volume button on your remote normally. The volume of headphone can be adjusted in Headphone Volume menu on screen.

Accessibility

> Settings > Accessibility

Accessibility function provides menu options and audio description to aid the visually or hearing impaired.

- **Menu Scheme**

Select menu scheme style from **Dark, Light**.

- **High Contrast Menu**

Improve contrast for visually impaired.

- **Menu Transparency**

Select menu transparency from **Off, Medium, High**.

- **Audio Type**

Audio Type

Select the audio type of programmes.

Voiceover Volume

Independently adjust the volume of voiceover.

- **Subtitle Settings**

Adjust Subtitle Settings for digital broadcast content.

Subtitle

Select whether to apply Subtitle to your TV. Select from **Off, Subtitle, Hard of Hearing Subtitles**.

Primary Subtitle

Set the default subtitle language for digital broadcast content.

Secondary Subtitle

Set the secondary subtitle language for digital broadcast content.

NOTE

- The above functions may not be applicable in some models/countries/regions.

Setting Time

> Settings > System > Time

Set the current time based on your location.

- **Time Format**

Set the time to display in a 12 or 24-hour format.

- **Date/Time**

Set the Date and Time. You can set the date and time to automatically sync with Internet/broadcast or manual setup by yourself.

- **Time Zone**

Select your time zone.

This function may not be applicable in some models/countries/regions.

- **Daylight Saving**

Select whether to apply Daylight Savings Time to the TV.

This function may not be applicable in some models/countries/regions.

Using the Timer

> Settings > System > Timer Settings

Adjust the timer settings to suit your preference.

- **Sleep Timer**

Set the sleep timer to automatically turn the TV Off within a specified time.

- **Power On Timer**

Set the clock for the time you want the TV to turn on automatically. You can set the time only once or set the time in specified date by weekly.

- **Power Off Timer**

Set the clock for the time you want the TV to turn off automatically. You can set the time only once or set the time in specified date by weekly.

- **Menu Timeout**

Set the amount of time that you would like for the menu to display.

- **Auto Sleep**

Set the amount of time that you would like for TV auto power off without any activity.

This function may not be applicable in some models/countries/regions.

- **Auto Standby with No Signal**

TV will go standby if there is no signal and the timer times out.

Using Parental Control

> Settings > System > Parental Control

Turn on Parental Control to block children from being able to view certain programmes.

If you have not set the PIN code before, create and confirm PIN window displays. Using the D-pad on your remote, create the password.

If you have set the PIN code before, enter PIN window displays.

Set PIN code at  >  Settings > System > System PIN.

- **Locks**

Turn on Locks to enable the Parental Control function.

You will see other Parental Control settings change from a greyed out state to highlighted. When this occurs, **Block Time, Channel Block, Content Block, Input Block, App Block, or Reset to Default** features are available to set.

- **Block Time**

Block the whole TV usage for a defined period of time, including Live TV, HDMI and apps.

- **Channel Block**

Block TV channels when you turn on the Parental Control feature. To use this function, please scan channels first.

- **Content Block**

Certain programme is blocked by age rating. The rating needs to be provided by the broadcaster.

- **Input Block**

Block content from devices that are connected to certain TV ports.

- **App Block**

Block access to certain apps.

Accessibility and System

● Reset to Default

Restore Parental Control back to the factory default setting.

Setting Language and Location

> Settings > System > Language and Location

Select the language used for this TV and your location.

● Location

Choose the location from where you will watch your TV.

● Menu Language

Set the default language for the TV menu.

● Primary Audio

Set the default audio output language for the type of digital broadcast content that you're viewing.

● Secondary Audio

Set the secondary audio output language for digital broadcast content.

● Digital Teletext

Adjust Teletext decoding.

Using Power Indicator

> Settings > System > Advanced Settings > Power Indicator

Set the Power Indicator light to stay **On** or **Off** when in standby mode.

> Settings > System > Advanced Settings > Indicator Light Setting

Set the indicator light from **Power**, **Always** or **Off**.

NOTE

- The above functions may not be applicable in some models/countries/ regions.

Enhanced Viewing

> Settings > System > Advanced Settings > Enhanced Viewing

You can turn on Enhanced Viewing features to enhance viewing experience.

● Automatic Content Recognition

Turn on Automatic Content Recognition (ACR) to enjoy amazing picture quality and audio quality adjustment for the content watching.

NOTE

- This function may not be applicable in some models/countries/ regions.
- To use this function, you should accept End User License Agreement and smart feature privacy policy/terms and conditions, and choose **Yes, Enable Enhanced Viewing** in the setting process.
- You will see the other Enhanced Viewing settings change from a greyed out state to highlighted. When this occurs, **Picture Mode Auto Adaptation** and **Sound Mode Auto Adaptation** features will be enabled.

● Picture Mode Auto Adaptation

Automatically switch to the best picture mode for the content watching. This function may not be applicable in some models/countries/regions.

● Sound Mode Auto Adaptation

Automatically switch to the best audio mode for the content watching.

This function may not be applicable in some models/countries/ regions.

Setting Usage Mode

> Settings > System > Advanced Settings > Usage Mode

Set the TV to use in Home or Store mode.

● Home Mode

Select Home Mode for normal TV usage, and use less energy.

If you want to switch to Store Mode when the TV is in Home Mode,

press  button to select  **Settings**, and select **System** > **Advanced Settings** > **Usage Mode**, and choose **Store Mode**.

● Store Mode

Select Store Mode, and the TV will be on display in a retail setting. This mode effects E-Pos and other demo functions, and is only intended for use in retail stores.

When Store Mode is selected, press  button on your remote control to enter store mode settings.

If you want to switch to Home Mode when the TV is in Store Mode,

press  button to select  **Settings**, and select **System** > **Advanced Settings** > **Usage Mode**, and choose **Home Mode**.

NOTE

- Enabling Store Mode could increase energy consumption.

Using Remote Control Service

> Settings > Support > Remote Control Service

Remote Control Service enables your TV to be controlled from the client server to let service agent diagnose the problem of your TV and dealing with the problem online efficiently.

To use this function:

- 1 Turn on **Remote Control Service**.
- 2 Select **Agree All** and **Confirm** in End User License Agreement page.
- 3 Select **Generate PIN** in Remote Control Service.
- 4 You can initiate a help request to service agent by hotline and provide the on-screen PIN.

NOTE

- This function may not be applicable in some models/countries/ regions.
- Steps above may vary. Please refer to the actual product.
- Keep the network connected when the Remote Control Service is running.

Upgrade

 >  **Settings > Support > System Upgrade**

Set your TV to receive the latest firmware.

- **Auto Firmware Upgrade**

Set your TV to automatically receive the latest firmware.

- **Check Firmware Upgrade**

Check to ensure that your TV has received the latest firmware.
Please ensure your TV is connected to the Internet.

- **Check OAD Upgrade**

Check to ensure that your TV has received the latest firmware via the tuner.

 **NOTE**

- Please ensure your TV is connected to the Internet.
- This function is only applicable when Thailand and Malaysia are selected in Location.

- **System App Auto Upgrade**

Set your system applications to automatically upgrade to the latest version. App auto upgrade will be done in the background. May need your confirmation on new Privacy Notices to complete upgrade in the progress.

- **Upgrade from USB**

Upgrade TV software from USB device.

 **NOTE**

- Please ensure the USB flash drive insert to USB 2.0 port of the TV.
- The updating files must be available in root directory.
- The format of the USB must be FAT32 and the partition table type must be MBR.

Reset to Factory Default

 >  **Settings > Support > Reset to Factory Default**

Restore your TV to the factory default. Reset will clear your personal setup and information.

Troubleshooting







Picture Issues

When the TV has a picture problem, these steps may help resolve the problem.

 >  **Settings > Support > Self Diagnosis > Picture Test**

Before you review the list of problems and solutions below, use **Picture Test** to determine if the problem is caused by the TV. **Picture Test** displays a high definition picture that you can examine for flaws or faults.

- If the test picture does not appear or there is noise or distortion, the TV may have a problem. Contact the service company in your country/region.
- If the test picture is displayed properly, there may be a problem with an external device. Please check the connections.
- If the problem persists, check the signal strength or refer to the external device's user manual.

The Problem	Possible Solutions
No picture, or black and white picture.	<ul style="list-style-type: none"> • Unplug the TV power cord from AC outlet and re-plug after 60 seconds. • Check if the Colour Saturation is set to 50 or higher at  >  Settings > Picture > Picture Mode Settings > Colour Saturation. • Try different TV channels.
The picture is distorted.	<ul style="list-style-type: none"> • The compression of video content may cause picture distortions, especially in fast moving pictures from sports programmes and action movies. • If the signal reception is weak or poor, screen distortion may be visible but it is not a malfunction. • Mobile phones used close to the TV (within 1m) may cause noise on analogue and digital channels.
The picture is blurry or flickering, or cuts out momentarily.	<ul style="list-style-type: none"> •  >  Settings > Picture > Picture Mode Settings > Sharpness. You can try to increase or decrease the Sharpness. • If you use an external antenna, check the direction, position and connection of the antenna. • Adjust the direction of your antenna, or reset or fine tune the channel.
The picture appears red, purple, pink and other colours.	<ul style="list-style-type: none"> •  >  Settings > Picture > Picture Mode Settings > Expert Settings > White Balance. You can try to increase or decrease the White Balance.
Picture distorted or appear wavy.	<ul style="list-style-type: none"> • Some electrical appliances may affect the TV. If you turn off the appliance and the interference goes away, then move it further away from TV. • Insert the power plug of the TV into another power outlet.

Sound Issues

When the TV has a sound problem, these steps may help resolve the problem.

 >  **Settings > Support > Self Diagnosis > Sound Test**

If the TV plays the **Sound Test** melody without distortion, there may be a problem with an external device or the broadcast signal's strength.



The Problem	Possible Solutions
There is no sound or the sound is too low at maximum volume.	<ul style="list-style-type: none"> • Check the volume control of the device (cable or satellite box, DVD, Blu-ray, etc.) connected to your TV.
Picture is normal, but no sound.	<ul style="list-style-type: none"> • Check the volume settings. • Check if 'Mute' mode is set to on.
The speakers are making an odd sound.	<ul style="list-style-type: none"> • Make sure that the audio cable is connected to the correct audio output connector on the external device . • For antenna or cable connections, check the signal information. • A low signal level may cause sound distortions.
Sound distorted or appears wavy.	<ul style="list-style-type: none"> • Some electrical appliances may affect the TV. If you turn off the appliance and the interference goes away, then move it further away from TV. • Insert the power plug of the TV set into another power outlet.
Sound is blurry or cuts out momentarily.	<ul style="list-style-type: none"> • If you use an external antenna, check the direction, position and connection of the antenna. • Adjust the direction of your antenna or reset or fine tune the channel.

Network Issues

When the TV has difficulties in connecting to the Internet, these steps may help resolve the problem.

 >  **Settings > Support > Self Diagnosis > Network Test**









If the TV network is connected, the screen will display Connected successfully.

The Problem	Possible Solutions
The TV cannot connect to your network or apps.	<ul style="list-style-type: none"> • Make sure the TV has a network connection. • Run  >  Settings > Support > Self Diagnosis > Network Test. • Contact your Internet service provider.
The wireless network connection failed.	<ul style="list-style-type: none"> • Make sure your wireless modem/router is on and connected to the Internet.
The wireless network signal is too weak.	<ul style="list-style-type: none"> • Position your wireless router, modem router, or access point in a central location. Avoid putting it in a corner.

Troubleshooting

External Device Connection Issues





When the TV has difficulties with external device connection, these solutions may help resolve the problem.

The Problem	Possible Solutions
I have connected an external source to my TV but I get no picture and/or sound.	<ul style="list-style-type: none"> Check whether the connection between the external device and your TV is correct. Make sure you have made the correct selection of input source.
The cable box is no signal or weak signal.	<ul style="list-style-type: none"> If there is no signal occasionally, unplug cable from TV and re-plug after 60 seconds. If there is always no signal, or the signal cannot be restored after plugging and unplugging, you can try  >  Settings > System > HDMI & CEC > HDMI Format, to confirm whether the signal can be recognised. Change to another HDMI port. Change to another HDMI cable.
There is no sound.	<ul style="list-style-type: none"> Check whether ARC is selected at  >  Settings > Sound > Speakers > Audio Output. If not, you need to check whether the external power amplifier device is connected to the ARC/eARC port or optical port of the TV.  >  Settings > Sound > Speakers > Digital Audio Output. You can try to select PCM, Dolby Digital, or Dolby Digital Plus. Whether the power amplifier device port is connected correctly. If you select HDMI as input, you can try  >  Settings > System > HDMI & CEC > HDMI Format.
The remote control does not work.	<ul style="list-style-type: none"> Confirm that TV still has power and is operational. Change the new batteries in the remote control. Check if the batteries are correctly installed. If some buttons don't work, but the volume buttons can work normally, it seems there is a problem with the application.

- Keyboards connected via USB or Bluetooth technology may not be usable with some Apps.

Apps

When some apps aren't playing, this may help resolve the problem.

The Problem	Possible Solutions
Netflix cannot be played.	<ul style="list-style-type: none">  >  Settings > System > Application Settings > Netflix > Forced Closure, then reopen to try. You can try to reset to the factory settings at  >  Settings > Support > Reset to Factory Default.

Media Files

When files aren't playing, this may help resolve the problem.

The Problem	Possible Solutions
Some files cannot be played.	<ul style="list-style-type: none"> Most files can be played back, but you might experience problems with corrupted files or files with high-bitrate, unsupported resolution, unsupported container or codec formats.

Voice Service Issues

When some Voice service aren't playing, this may help resolve the problem.

The Problem	Possible Solutions
Alexa cannot be played.	<ul style="list-style-type: none"> For more information about Alexa, please refer to Smart Functions > Using Voice Service > Alexa in this manual.
Google assistant cannot be played.	<ul style="list-style-type: none"> You can try to log in Google account. If you receive "I don't understand" of the voice recognition, please change account or log out the account. After logging in to the Google account, the recognition language may be different. You need to log in to the Google account on the web page to set the voice language. For more information about Google Assistant, please refer to Smart Functions > Using Voice Service > Google Assistant in this manual.

TV Status Diagnosis

 >  **Settings > Support > Self Diagnosis**

Perform self diagnosis to test sound, picture and connections. Use **Picture Test** to help diagnose video issues and **Sound Test** to diagnose sound issues. You can also view signal strength information for over-the-air digital signals by using **Network Test** and **Input Connection Test**. Additionally, you can view the status of the TV by using **Status Check**.

Troubleshooting

Recording/Timeshift Issues

When **Timeshift** or **Schedule recording** isn't working, these steps may help resolve the problem.

The Problem	Possible Solutions
Schedule Recording cannot be used.	<ul style="list-style-type: none">• Check if there is a storage device connected to the TV.• Check the free space of the storage device. The function will not work if there isn't enough storage space in the device.• Check whether your storage device is damaged. If so, it is suggested to format your storage device.• Recording will automatically stop if the signal becomes too weak.• Recording or timeshift function may not work because of the slow speed of read-write for USB flash drive.• Recording or timeshift function may not work because the storage format of your device is unsupported.

• The Recording/Timeshift functions may not be applicable in some models/ countries/regions.

Other Issues

Use these procedures to resolve other issues that may occur.

The Problem	Possible Solutions
The TV is hot.	<ul style="list-style-type: none">• Watching TV for an extended period of time causes the panel to generate heat. The heat from the panel is dissipated through internal vents running along the top of the TV.• After extended use, you may feel hot when touching it. This heat, however, is not a defect and does not affect the TV's functionality.
The TV smells of plastic.	<ul style="list-style-type: none">• This smell is normal and will dissipate over time.
The plastic cabinet makes a "clicking" type of sound.	<ul style="list-style-type: none">• The "clicking" sound can be caused when the temperature of the TV changes. This change causes the TV cabinet to expand or contract, which makes the sound. This is normal and the TV is OK.
When I turn on my TV, there is a delay for a few seconds before the picture appears. Is this normal?	<ul style="list-style-type: none">• Yes, this is normal. The TV is initializing and searching for previous setting information.

Other Information

Specifications

Features, appearance and specifications are subject to change without notice.

Item		43"	50"	55"	65"
Dimension (W × H × D)	Without Stand	963 × 560 × 74 mm	1117 × 646 × 74 mm	1233 × 711 × 74 mm	1452 × 834 × 74 mm
	With Stand	963 × 598 × 213 mm	1117 × 692 × 226 mm	1233 × 758 × 236 mm	1452 × 894 × 307 mm
Weight	Without Stand	6.8 kg	9.8 kg	11.3 kg	16.4 kg
	With Stand	7.2 kg	10.0 kg	11.6 kg	16.8 kg
Active Screen Size (Diagonal)		108 cm	126 cm	139 cm	164 cm
Screen resolution		3840 × 2160	3840 × 2160	3840 × 2160	3840 × 2160
Audio power		7 W + 7 W	8 W + 8 W	8 W + 8 W	10 W + 10 W
Power consumption		80 W	130 W	130 W	150 W
Power supply		100-240V~ 50/60Hz			
Operating mode power density		0.016 Watts/cm ²	0.020 Watts/cm ²	0.016 Watts/cm ²	0.013 Watts/cm ²
Power consumption when turned off		N.A.			
Power consumption in standby mode		0.5 W			
Receiving systems	Analog	PAL-D/K, B/G, I, SECAM-D/K, B/G			
	Digital	DVB-T/T2, DVB-C, DVB-S/S2			
Wireless LAN Module specifications	Model	ZDGF7668AU-T			
	Frequency Range	2.4-2.4835GHz 5.15-5.85GHz			
	Output Power (Max.)	2.4-2.4835GHz 17dBm			
		5.15-5.25GHz 14dBm			
5.25-5.35GHz(DFS Band) 14dBm					
5.49-5.71GHz(DFS/TPC Band) 14dBm					
Bluetooth Module specifications		5.725-5.85GHz(for Non EU) 14dBm			
Bluetooth Module specifications	Model	ZDGF7668AU-T			
	Frequency Range	2.4-2.4835GHz			
	Output Power (Max.)	2.4-2.4835GHz, Class1, 6dBm			
Environmental conditions		Temperature: 5°C - 45°C Humidity: 20% - 80% RH Atmospheric pressure: 86 kPa - 106 kPa			
HDMI Input		RGB / 60Hz (640×480, 800×600, 1024×768, 1280×768, 1360×768, 1280×1024) YUV / 60Hz (480i, 480p, 720p, 1080i, 1080p) YUV / 50Hz (576i, 576p, 720p, 1080i, 1080p) YUV / 24Hz (720p, 1080p) YUV / 25Hz (1080p) YUV / 30Hz (720p, 1080p) 3840x2160 4:2:0 50/60p 3840x2160 4:4:4 30/25/24p 3840x2160 4:2:2 30/25/24p 3840x2160 4:4:4 60p 4096x2160 4:2:0 50/60p 4096x2160 4:4:4 30/25/24p 4096x2160 4:2:2 30/25/24p			

Other Information

License Information

- The terms HDMI and HDMI High-Definition Multimedia Interface, and the HDMI Logo are trademarks or registered trademarks of HDMI Licensing Administrator, Inc. in the United States and other countries.



- DVB is a registered trademark of the DVB Project.
- [1] EIA/CEA-861-D compliance covers the transmission of uncompressed digital video with high-bandwidth digital content protection, which is being standardized for reception of high-definition video signals. Because this is an evolving technology, it is possible that some devices may not operate properly with the television.

MP3 licence letter

MPEG Layer-3 audio coding technology licensed from Fraunhofer IIS and Thomson.

MP4 licence letter

THIS PRODUCT IS LICENSED UNDER THE MPEG-4 VISUAL PATENT PORTFOLIO LICENSE FOR THE PERSONAL AND NON-COMMERCIAL USE OF A CONSUMER FOR (I) ENCODING VIDEO IN COMPLIANCE WITH THE MPEG-4 VISUAL STANDARD (MPEG-4 VIDEO) AND/OR (II) DECODING MPEG-4 VIDEO THAT WAS ENCODED BY A CONSUMER ENGAGED IN A PERSONAL AND NON-COMMERCIAL ACTIVITY AND/OR WAS OBTAINED FROM A VIDEO PROVIDER LICENSED BY MPEG LA TO PROVIDE MPEG-4 VIDEO. NO LICENSE IS GRANTED OR SHALL BE IMPLIED FOR ANY OTHER USE. ADDITIONAL INFORMATION INCLUDING THAT RELATING TO PROMOTIONAL, INTERNAL AND COMMERCIAL USES AND LICENSING MAY BE OBTAINED FROM MPEG LA, L.L.C. SEE [HTTP://WWW.MPEGLA.COM](http://www.mpegla.com)

AVC licence letter

THIS PRODUCT IS LICENSED UNDER THE AVC PATENT PORTFOLIO LICENSE FOR THE PERSONAL AND NONCOMMERCIAL USE OF A CONSUMER TO (I) ENCODE VIDEO IN COMPLIANCE WITH THE AVC STANDARD ("AVC VIDEO") AND/OR (II) DECODE AVC VIDEO THAT WAS ENCODED BY A CONSUMER ENGAGED IN A PERSONAL AND NON-COMMERCIAL ACTIVITY AND/OR WAS OBTAINED FROM A VIDEO PROVIDER LICENSED TO PROVIDE AVC VIDEO. NO LICENSE IS GRANTED OR SHALL BE IMPLIED FOR ANY OTHER USE. ADDITIONAL INFORMATION MAY BE OBTAINED FROM MPEG LA, L.L.C. SEE [HTTP://WWW.MPEGLA.COM](http://www.mpegla.com)

Licence Notification

TRADEMARK ACKNOWLEDGMENT



Dolby, Dolby Vision, Dolby Atmos, and the double-D symbol are registered trademarks of Dolby Laboratories Licensing Corporation. Manufactured under license from Dolby Laboratories. Confidential unpublished works. Copyright © 2012-2021 Dolby Laboratories. All rights reserved.

Disposal of Used Electrical & Electronic Equipment

Packaging and electrical goods should be recycled appropriately, and not treated as household waste. Please dispose of this equipment at your applicable collection point for the recycling of electrical & electronic equipment waste. By ensuring the correct disposal of this product, you will help prevent potentially hazardous to the environment and to human health, which could otherwise be caused by unsuitable waste handling of this product. The recycling of materials will help conserve natural resources. Please do not therefore dispose of your old electrical and electronic equipment with your household waste. For more detailed information about recycling of this product, please contact your local city office, your household waste disposal service or the shop where you purchased the product.

